

DAECO

UNI

FLANGE
FLANGES

Dimensioni delle flange secondo UNI 2223



Diametro Nominale DN	PN ≤ 2,5				PN 6				PN 10				PN 16				PN 25			
	a	D	f	N. fori	Diametro delle viti	a	D	f	N. fori	Diametro delle viti	a	D	f	N. fori	Diametro delle viti	a	D	f	N. fori	Diametro delle viti
10	50	75	11	4	M10	50	75	11	4	M10	60	90	14	4	M12	60	90	14	4	M12
15	55	80	11	4	M10	55	80	11	4	M10	65	95	14	4	M12	65	95	14	4	M12
20	65	90	11	4	M10	65	90	11	4	M10	75	105	14	4	M12	75	105	14	4	M12
25	75	100	11	4	M10	75	100	11	4	M10	85	115	14	4	M12	85	115	14	4	M12
32	90	120	14	4	M12	90	120	14	4	M12	100	140	18	4	M16	100	140	18	4	M16
40	100	130	14	4	M12	100	130	14	4	M12	110	150	18	4	M16	110	150	18	4	M16
50	110	140	14	4	M12	110	140	14	4	M12	125	165	18	4	M16	125	165	18	4	M16
65	130	160	14	4	M12	130	160	14	4	M12	145	185	18	4	M16	145	185	18	8	M16
80	150	190	18	4	M16	150	190	18	4	M16	160	200	18	4	M16	160	200	18	8	M16
100	170	210	18	4**	M16	170	210	18	8	M16	180	220	18	8	M16	180	220	18	8	M16
125	200	240	18	8	M16	200	240	18	8	M16	210	250	18	8	M16	220	270	25*	8	M22
150	225	265	18	8	M16	225	265	18	8	M16	240	285	22	8	M20	240	285	22	8	M20
175	255	295	18	8	M16	255	295	18	8	M16	270	315	22	8	M20	270	315	22	8	M20
200	280	320	18	8	M16	280	320	18	8	M16	295	340	22	8	M20	295	340	22	12	M20
250	335	375	18	12	M16	335	375	18	12	M16	350	395	22	12	M20	355	405	25*	12	M22
300	395	440	22	12	M20	395	440	22	12	M20	400	445	22	12	M20	410	460	25*	12	M22
350	445	490	22	12	M20	445	490	22	12	M20	460	505	22	16	M20	470	520	25*	16	M22
400	495	540	22	16	M20	495	540	22	16	M20	515	565	25*	16	M22	525	580	30	16	M27
450	550	595	22	16	M20	550	595	22	16	M20	565	615	25*	20	M22	585	640	30	20	M27
500	600	645	22	20	M20	600	645	22	20	M20	620	670	25*	20	M22	650	715	33	20	M30
600	705	755	25*	20	M22	705	755	25*	20	M22	725	780	30	20	M27	770	840	36	20	M33
700	810	860	25*	24	M22	810	860	25*	24	M22	840	895	30	24	M27	840	910	36	24	M33
800	920	975	30	24	M27	920	975	30	24	M27	950	1015	33	24	M30	950	1025	39	24	M36
900	1020	1075	30	24	M27	1020	1075	30	24	M27	1050	1115	33	28	M30	1050	1125	39	28	M36
1000	1120	1175	30	28	M27	1120	1175	30	28	M27	1160	1230	36	28	M33	1170	1255	42	28	M39
1200	1320	1375	30	32	M27	1340	1405	33	32	M30	1380	1455	39	32	M36	1390	1485	48	32	M45
1400	1520	1575	30	36	M27	1560	1630	36	36	M33	1590	1675	42	36	M39	1590	1685	48	36	M45
1600	1730	1790	30	40	M27	1760	1830	36	40	M33	1820	1915	48	40	M45	1820	1930	56	40	M52
1800	1930	1990	30	44	M27	1970	2045	39	44	M36	2020	2115	48	44	M45	2020	2130	56	44	M52
2000	2130	2190	30	48	M27	2180	2265	42	48	M39	2230	2325	48	48	M45	2230	2345	62	48	M56

* Il diametro 25 è stato introdotto per consentire l'accoppiamento anche con viti di 24 mm di diametro



Diametro Nominale DN	PN 40				PN 64				PN 100				PN 160				PN 250								
	a	D	f	N. fori	Diametro delle viti	a	D	f	N. fori	Diametro delle viti	a	D	f	N. fori	Diametro delle viti	a	D	f	N. fori	Diametro delle viti					
10	60	90	14	4	M12	70	100	14	4	M12	70	100	14	4	M12	70	100	14	4	M12	85	125	18	4	M16
15	65	95	14	4	M12	75	105	14	4	M12	75	105	14	4	M12	75	105	14	4	M12	90	130	18	4	M16
20	75	105	14	4	M12	90	130	18	4	M16	90	130	18	4	M16	90	130	18	4	M16	95	135	18	4	M16
25	85	115	14	4	M12	100	140	18	4	M16	100	140	18	4	M16	100	140	18	4	M16	105	150	22	4	M20
32	100	140	18	4	M16	110	155	22	4	M20	110	155	22	4	M20	110	155	22	4	M20	120	165	22	4	M20
40	110	150	18	4	M16	125	170	22	4	M20	125	170	22	4	M20	125	170	22	4	M20	135	185	25*	4	M22
50	125	165	18	4	M16	135	180	22	4	M20	145	195	25*	4	M22	145	195	25*	4	M22	150	200	25*	8	M22
65	145	185	18	8	M16	160	205	22	8	M20	170	220	25*	8	M22	170	220	25*	8	M22	180	230	25*	8	M22
80	160	200	18	8	M16	170	215	22	8	M20	180	230	25*	8	M22	180	230	25*	8	M22	200	255	30	8	M27
100	190	235	22	8	M20	200	250	25*	8	M22	210	265	30	8	M27	210	265	30	8	M27	235	300	33	8	M30
125	220	270	25*	8	M22	240	295	30	8	M27	250	315	33	8	M30	250	315	33	8	M30	275	340	33	12	M30
150	250	300	25*	8	M22	280	345	33	8	M30	290	355	33	12	M30	290	355	33	12	M30	320	390	36	12	M33
175	295	350	30	12	M27	310	375	33	12	M30	320	385	33	12	M30	320	390	36	12	M30	355	430	39	12	M36
200	320	375	30	12	M27	345	415	36	12	M33	360	430	36	12	M33	360	430	36	12	M33	400	485	42	12	M39
250	385	450	33	12	M30	400	470	36	12	M33	430	505	39	12	M36	430	515	42	12	M36	490	585	48	16	M45
300	450	515	33	16	M30	460	530	36	16	M33	500	585	42	16	M39	500	585	42	16	M39					
350	510	580	36	16	M33	525	600	39	16	M36	560	655	48	16	M45	560	655	48	16	M45					
400	585	660	39	16	M36	585	670	42	16	M39	620	715	48	16	M45	620	715	48	16	M45					
450	610	685	39	20	M36	630	715	42	20	M39	675	770	48	20	M45	675	770	48	20	M45					
500	670	755	42	20	M39	705	800	48	20	M45	760	870	56	20	M52	760	870	56	20	M52					
600	795	890	48	20	M45	820	930	56	20	M52	875	990	62	20	M56	875	990	62	20	M56					
700	900	995	48	24	M45	935	1045	56	24	M52	1020	1145	70	24	M64	1020	1145	70	24	M64					
800	1030	1140	56	24	M52	1050	1165	62	24	M56															
900	1140	1250	56	28	M52	1170	1285	62	28	M56															
1000	1250	1360	56	28	M52	1290	1415	70	28	M64															
1200	1460	1575	62	32	M56	1530	1665	78	32	M72															
1400	1680	1795	62	36	M56																				
1600	1900	2025	70	40	M64																				
1800																									
2000																									

* Il diametro 25 è stato introdotto per consentire l'accoppiamento anche con viti di 24 mm di diametro

Bulloni per Flange da PN. 6 a PN. 64

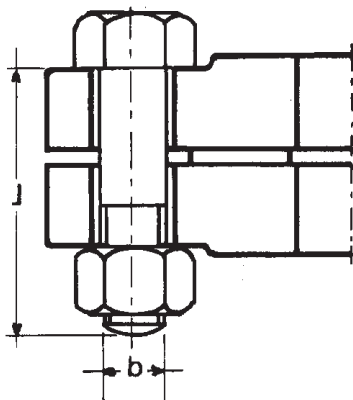

DN	PN 6				PN 10				PN 16				PN 25				PN 40				PN 64			
	N.	d	L	gr. ~	N.	d	L	gr. ~	N.	d	L	gr. ~	N.	d	L	gr. ~	N.	d	L	gr. ~	N.	d	L	gr. ~
10	4	10	40	60	4	12	50	95	4	12	50	95	4	12	50	95	4	12	50	95	4	12	65	130
15	4	10	40	60	4	12	50	95	4	12	50	95	4	12	50	95	4	12	50	95	4	12	65	130
20	4	10	45	70	4	12	50	100	4	12	50	95	4	12	55	100	4	12	55	100	4	16	70	250
25	4	10	45	70	4	12	50	100	4	12	50	95	4	12	55	100	4	12	55	100	4	16	75	280
32	4	12	45	90	4	16	60	230	4	16	60	230	4	16	60	230	4	16	60	230	4	20	80	420
40	4	12	45	90	4	16	60	230	4	16	60	230	4	16	60	230	4	16	60	230	4	20	85	450
50	4	12	45	90	4	16	60	230	4	16	60	230	4	16	65	240	4	16	65	240	4	20	85	450
65	4	12	45	90	4	16	60	230	4	16	60	230	8	16	70	250	8	16	70	250	8	20	85	450
80	4	16	60	230	4	16	65	240	8	16	65	240	8	16	70	250	8	16	70	250	8	20	90	500
100	4	16	60	230	8	16	65	240	8	16	65	240	8	20	75	400	8	20	80	420	8	22	95	900
125	8	16	65	240	8	16	70	250	8	16	70	250	8	22	80	550	8	22	80	550	8	27	110	1090
150	8	16	65	240	8	20	75	400	8	20	75	400	8	22	90	800	8	22	90	800	8	30	115	1200
200	8	16	70	250	8	20	80	420	12	20	80	420	12	22	90	800	12	27	100	1000	12	33	130	1900
250	12	16	70	250	12	20	85	450	12	22	85	600	12	27	100	1000	12	30	110	1150	12	33	140	2050
300	12	20	75	400	12	20	85	450	12	22	90	800	16	27	100	1000	16	30	120	1340	16	33	150	2150
350	12	20	80	420	16	20	85	450	16	22	95	850	16	30	110	1150	16	33	130	1900	16	36x3	165	2500
400	16	20	80	420	16	22	85	600	16	27	105	1050	16	33	120	1700	16	36x3	140	2300	16	39x3	175	3150
450	16	20	80	420	20	22	85	600	20	27	105	1050	20	33	120	1700	20	36x3	140	2300	-	-	-	-
500	20	20	80	420	20	22	90	800	20	30	110	1150	20	33	120	1700	20	39x3	150	2900	-	-	-	-
600	20	22	85	600	20	27	95	980	20	33	115	1600	20	36x3	140	2300	20	45x3	170	4400	-	-	-	-
700	24	22	85	600	24	27	100	1000	24	33	115	1600	24	39x3	150	2900	24	45x3	180	4500	-	-	-	-
800	24	27	90	950	24	30	105	1190	24	36x3	135	2200	24	45x3	150	4160	24	52x3	200	7000	-	-	-	-
900	24	27	95	980	28	30	110	1150	28	36x3	135	2200	28	45x3	170	4400	28	52x3	210	7200	-	-	-	-
1000	28	27	95	980	28	33	115	1600	28	39x3	140	2800	28	52x3	180	6700	28	52x3	220	7400	-	-	-	-
1200	32	30	100	1150	32	36x3	125	2100	32	45x3	160	4300	-	-	-	-	-	-	-	-	-	-	-	-
1400	36	33	110	1500	36	39x3	135	2600	36	45x3	165	4350	-	-	-	-	-	-	-	-	-	-	-	-
1600	40	33	115	1600	40	45x3	150	4160	40	52x3	185	6800	-	-	-	-	-	-	-	-	-	-	-	-
1800	44	36x3	120	2000	44	45x3	160	4300	44	52x3	195	6900	-	-	-	-	-	-	-	-	-	-	-	-
2000	48	39x3	130	2500	48	45x3	170	4400	48	56x4	205	-	-	-	-	-	-	-	-	-	-	-	-	-

Norme generali di fornitura e tolleranze per flange secondo UNI 6100-67

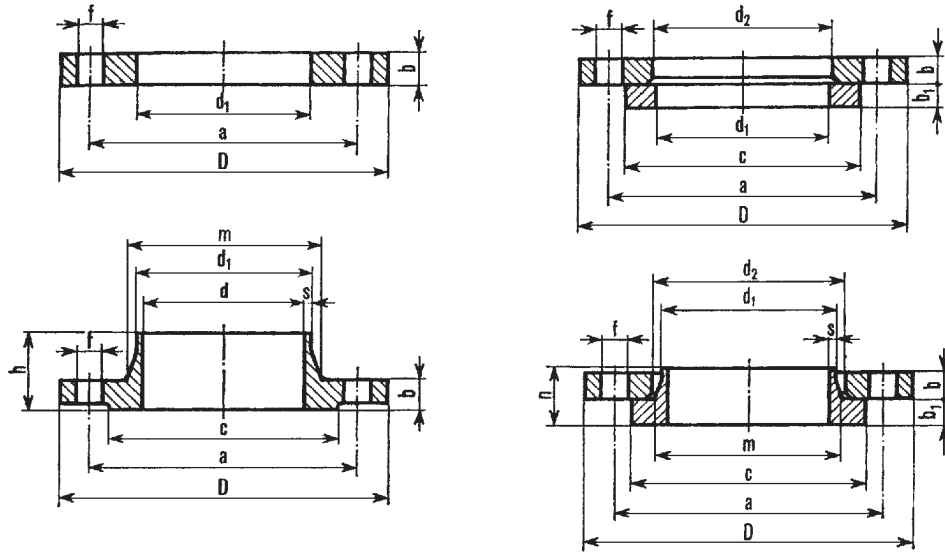

RIFERIMENTI		GRUPPO DI DIMENSIONI	ESECUZIONE LAVORATA	
D Diametro esterno		fino a 200	± 1,0	
		oltre 200 fino a 300	± 1,5	
		oltre 300 fino a 400	± 2,0	
		oltre 400	± 2,0	
d Diametro		fino a 100	± 0,5 0	
		oltre 100 fino a 400	± 1,0 0	
		oltre 400	± 1,5 0	
d1 Diametro	Per flange da saldare di testa e collari d'appoggio	fino a 100	± 0,5 0	
		oltre 100 fino a 400	± 1,0 - 0,5 ± 1,5 - 1,0	
d1 Diametro	Per flange ed anelli da saldare a sovrapposizione	fino a 80	± 0,5 0	
		oltre 80 fino a 350	± 1,0 0	
		oltre 350 fino a 400	± 1,5 0	
		oltre 400	± 5,0	
d2 Diametro		fino a 400	± 1,0 0	
		oltre 400	± 1,5 0	
b - b1 Spessori		fino a 10	Su entrambe le superfici	± 0,5
		oltre 10 fino a 20		± 0,8
		oltre 20 fino a 30		± 1,0
		oltre 30 fino a 50		± 1,0
		oltre 50		± 1,5
			Su una superficie	± 1,0
				± 1,3
				± 1,5
				± 1,5
				± 2,0

RIFERIMENTI		GRUPPO DI DIMENSIONI	ESECUZIONE LAVORATA
m Diametro codolo		-	± 1,0 0
		fino a 80	± 1,5
h Altezza		oltre 80 fino a 250	± 2,0
		oltre 250	± 3,0
s Spessore codolo		fino a 100	± 1,0 0
		oltre 100 fino a 400	± 1,5 0
		oltre 400	± 2,0 0
C Diametro gradino		fino a 80	0 - 1,0
		oltre 80 fino a 300	0 - 2,0
		oltre 300	0 - 3,0
a Diametro cerchio fori		fino a 250	± 0,5
		oltre 250 fino a 600	± 0,8
		oltre 600	± 1,2
Distanza tra i centri dei fori (misurata sulla corda)		-	± 0,4
Concentricità del cerchio dei fori e della superficie di tenuta rispetto al foro centrale		-	0,8
Parallelismo superficie		-	1°

NORME GENERALI DI FORNITURA

Le flange possono essere fornite con gradino di tenuta UNI 2229-67. Con incameratura semplice, maschio (SM) o femmina (SF) secondo UNI 2225-67. Con incameratura doppia, maschio (DM) o femmina (DF) secondo UNI 2226-67.

La lavorazione all'utensile della superficie di appoggio delle teste delle viti e dei dadi può non essere fatta, purchè tale superficie risulti piana e parallela alla superficie di tenuta in modo da assicurare il regolare assestamento dei bulloni al serraggio.

Per la finitura delle superfici di appoggio delle guarnizioni vedere tabella pag. 128.

Flange piane da saldare a sovrapposizione



UNI 6082-67 PN. 2,5

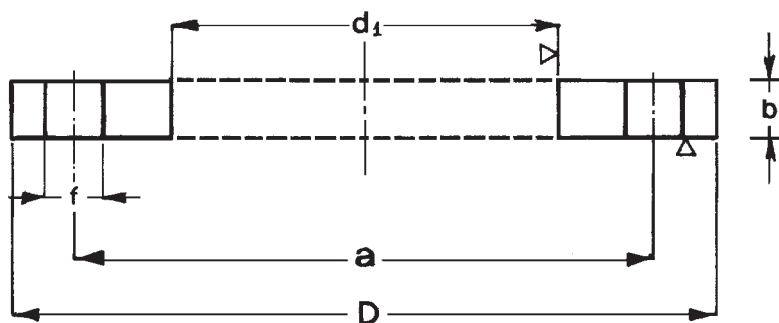

DN	Ø TUBO		d ₁		a	D	b	f	VITI	N. FORI	Kg.
	DIN	ISO	DIN	ISO							
10	13,5	17,2	14,0	17,5	50	75	10	11	M10	4	0,29
15	20,0	21,3	20,5	22,0	55	80	10	11	M10	4	0,33
20	25,0	26,9	25,5	27,5	65	90	12	11	M10	4	0,50
25	30,0	33,7	30,5	34,0	75	100	12	11	M10	4	0,61
32	38,0	42,4	38,5	43,0	90	120	14	14	M12	4	1,05
40	44,5	48,3	45,0	49,0	100	130	14	14	M12	4	1,23
50	57,0	60,3	58,0	61,5	110	140	14	14	M12	4	1,35
65	76,1		77,0		130	160	14	14	M12	4	1,68
80	88,9		90,0		150	190	16	18	M16	4	2,63
100	108,0	114,3	109,0	115,5	170	210	16	18	M16	4	2,92
125	133,0	139,7	134,5	141,0	200	240	18	18	M16	8	3,90
150	159,0	168,3	160,5	170,0	225	265	20	18	M16	8	4,78
200	219,1		221,0		280	320	20	18	M16	8	5,03
250	267,0	273,0	269,0	275,0	335	375	20	18	M16	12	7,54
300	323,9		326,0		395	440	22	22	M20	12	11,1
350	368,0	355,6	370,5	358,0	445	490	22	22	M20	12	14,4
400	419,0	406,4	422,0	409,0	495	540	22	22	M20	16	15,8
450	457,2		460,2		550	595	22	22	M20	16	20,2
500	508,0		511,0		600	645	22	22	M20	20	22,0
600	609,6		612,6		705	755	24	25	M22	20	30,3
700	711,2		714,2		810	860	26	25	M22	24	39,0
800	812,8		815,8		920	975	30	30	M27	24	55,5
900	914,4		917,4		1020	1075	32	30	M27	24	66,3
1000	1016,0		1019,0		1120	1175	34	30	M27	28	77,4
1200	1220,0		1224,0		1320	1375	36*	30	M27	32	—
1400	1420,0		1424,0		1520	1575	38*	30	M27	36	—
1600	1620,0		1624,0		1730	1790	40*	30	M27	40	—
1800	1820,0		1824,0		1930	1990	42*	30	M27	44	—
2000	2020,0		2024,0		2130	2190	44*	30	M27	48	—

N.B. Le dimensioni delle flange segnate con asterisco non sono previste dalle norme UNI 6082
I dati sono desunti dalle norme UNI 2223

* Lo Spessore è indicativo

Flange piane da saldare a sovrapposizione



UNI 2276-67 PN.6

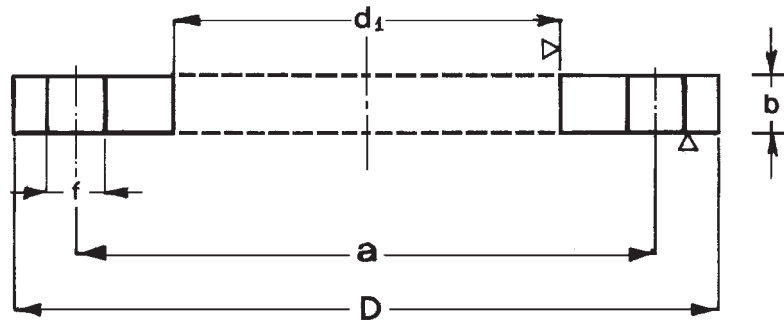

DN	Ø TUBO		d ₁		a	D	b	f	VITI	N. FORI	Kg.
	DIN	ISO	DIN	ISO							
10	13,5	17,2	14,0	17,5	50	75	10	11	M10	4	0,29
15	20,0	21,3	20,5	22,0	55	80	10	11	M10	4	0,33
20	25,0	26,9	25,5	27,5	65	90	12	11	M10	4	0,50
25	30,0	33,7	30,5	34,0	75	100	12	11	M10	4	0,61
32	38,0	42,4	38,5	43,0	90	120	14	14	M12	4	1,05
40	44,5	48,3	45,0	49,0	100	130	14	14	M12	4	1,23
50	57,0	60,3	58,0	61,5	110	140	14	14	M12	4	1,35
65	76,1		77,0		130	160	14	14	M12	4	1,68
80	88,9		90,0		150	190	16	18	M16	4	2,63
100	108,0	114,3	109,0	115,5	170	210	16	18	M16	4	2,92
125	133,0	139,7	134,5	141,0	200	240	18	18	M16	8	3,90
150	159,0	168,3	160,5	170,0	225	265	20	18	M16	8	4,78
200	219,1		221,0		280	320	22	18	M16	8	6,91
250	267,0	273,0	269,0	275,0	335	375	24	18	M16	12	9,04
300	323,9		326,0		395	440	24	22	M20	12	12,1
350	368,0	355,6	370,5	358,0	445	490	26	22	M20	12	17,0
400	419,0	406,4	422,0	409,0	495	540	28	22	M20	16	20,1
450	457,2		460,2		550	595	28	22	M20	16	25,8
500	508,0		511,0		600	645	30	22	M20	20	30,0
600	609,6		612,6		705	755	30	25	M22	20	37,9
700	711,2		714,2		810	860	32	25	M22	24	47,9
800	812,8		815,8		920	975	34	30	M27	24	62,9
900	914,4		917,4		1020	1075	36	30	M27	24	74,6
1000	1016,0		1019,0		1120	1175	36	30	M27	28	81,9
1200	1220,0		1224,0		1340	1405	38*	33	M30	32	—
1400	1420,0		1424,0		1560	1630	40*	36	M33	36	—
1600	1620,0		1624,0		1760	1830	42*	36	M33	40	—
1800	1820,0		1824,0		1970	2045	44*	39	M36x3	44	—
2000	2020,0		2024,0		2180	2265	46*	42	M39x3	48	—

N.B. Le dimensioni delle flange segnate con asterisco non sono previste dalle norme UNI 2276
I dati sono desunti dalle norme UNI 2223

* Lo spessore è indicativo

Flange piane da saldare a sovrapposizione



UNI 2277-67 PN.10

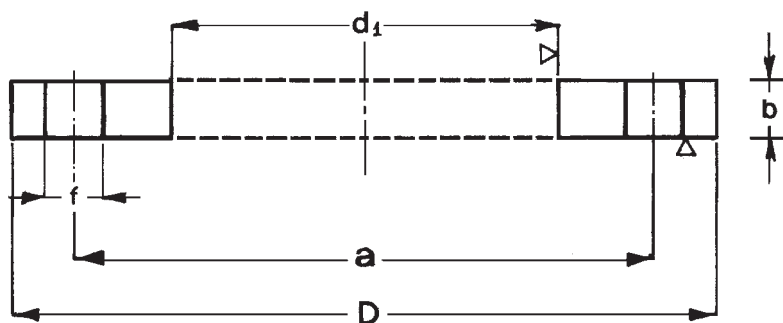

DN	Ø TUBO		d ₁		a	D	b	f	VITI	N. FORI	Kg.
	DIN	ISO	DIN	ISO							
10	13,5	17,2	14,0	17,5	60	90	12	14	M12	4	0,52
15	20,0	21,3	20,5	22,0	65	95	12	14	M12	4	0,66
20	25,0	26,9	25,5	27,5	75	105	14	14	M12	4	0,82
25	30,0	33,7	30,5	34,0	85	115	14	14	M12	4	1,01
32	38,0	42,4	38,5	43,0	100	140	16	18	M16	4	1,63
40	44,5	48,3	45,0	49,0	110	150	16	18	M16	4	1,85
50	57,0	60,3	58,0	61,5	125	165	18	18	M16	4	2,46
65	76,1		77,0		145	185	18	18	M16	4	3,00
80	88,9		90,0		160	200	20	18	M16	4	3,61
100	108,0	114,3	109,0	115,5	180	220	22	18	M16	8	4,40
125	133,0	139,7	134,5	141,0	210	250	24	18	M16	8	5,92
150	159,0	168,3	160,5	170,0	240	285	24	22	M20	8	7,17
200	219,1		221,0		295	340	26	22	M20	8	10,1
250	267,0	273,0	269,0	275,0	350	395	28	22	M20	12	12,9
300	323,9		326,0		400	445	28	22	M20	12	14,8
350	368,0	355,6	370,5	358,0	460	505	30	22	M20	16	22,0
400	419,0	406,4	422,0	409,0	515	565	32	25	M22	16	28,0
450	457,2		460,2		565	615	32	25	M22	20	33,3
500	508,0		511,0		620	670	34	25	M22	20	40,3
600	609,6		612,6		725	780	36	30	M27	20	53,0
700	711,2		714,2		840	895	38	30	M27	24	65,0
800	812,8		815,8		950	1015	40	33	M30	24	88,0
900	914,4		917,4		1050	1115	42	33	M30	28	100,0
1000	1016,0		1019,0		1160	1230	44	36	M33	28	128,0
1200	1220,0		1224,0		1380	1455	46*	39	M36x3	32	
1400	1420,0		1424,0		1590	1675	48*	42	M39x3	36	
1600	1620,0		1624,0		1820	1915	50*	48	M45x3	40	
1800	1820,0		1824,0		2020	2115	52*	48	M45x3	44	
2000	2020,0		2024,0		2230	2325	54*	48	M45x3	48	

N.B. Le dimensioni delle flange segnate con asterisco non sono previste dalle norme UNI 2277
I dati sono desunti dalle norme UNI 2223

* Lo spessore è indicativo

Flange piane da saldare a sovrapposizione

UNI 2278-67 PN.16

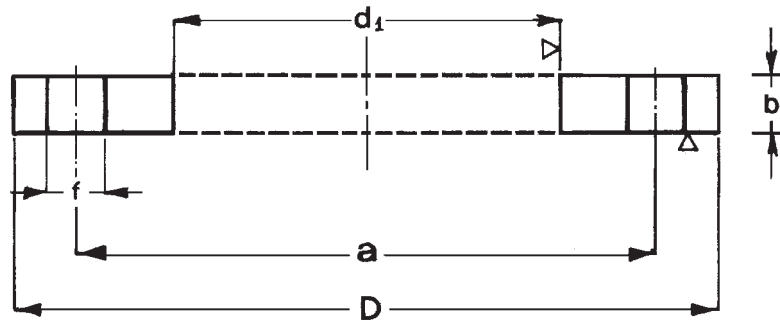

DN	Ø TUBO		d ₁		a	D	b	f	VITI	N. FORI	Kg.
	DIN	ISO	DIN	ISO							
10	13,5	17,2	14,0	17,5	60	90	12	14	M12	4	0,52
15	20,0	21,3	20,5	22,0	65	95	12	14	M12	4	0,66
20	25,0	26,9	25,5	27,5	75	105	14	14	M12	4	0,82
25	30,0	33,7	30,5	34,0	85	115	14	14	M12	4	1,01
32	38,0	42,4	38,5	43,0	100	140	16	18	M16	4	1,63
40	44,5	48,3	45,0	49,0	110	150	16	18	M16	4	1,85
50	57,0	60,3	58,0	61,5	125	165	18	18	M16	4	2,46
65	76,1		77,0		145	185	18	18	M16	4	3,00
80	88,9		90,0		160	200	20	18	M16	8	3,61
100	108,0	114,3	109,0	115,5	180	220	22	18	M16	8	4,40
125	133,0	139,7	134,5	141,0	210	250	24	18	M16	8	5,92
150	159,0	168,3	160,5	170,0	240	285	24	22	M20	8	7,17
200	219,1		221,0		295	340	26	22	M20	12	9,77
250	267,0	273,0	269,0	275,0	355	405	32	25	M22	12	16,0
300	323,9		326,0		410	460	32	25	M22	12	19,3
350	368,0	355,6	370,5	358,0	470	520	36	25	M22	16	29,4
400	419,0	406,4	422,0	409,0	525	580	38	30	M27	16	36,5
450	457,2		460,2		585	640	40	30	M27	20	42,0
500	508,0		511,0		650	715	42	33	M30	20	51,0
600	609,6		612,6		770	840	44	36	M33	20	70,0
700	711,2		714,2		840	910	46	36	M33	24	88,0
800	812,8		815,8		950	1025	48	39	M36x3	24	115,0
900	914,4		917,4		1050	1125	50	39	M36x3	28	125,0
1000	1016		1019		1170	1255	50	42	M39x3	28	160,0
1200	1220		1224		1390	1485	52*	48	M45x3	32	
1400	1420		1424		1590	1685	54*	48	M45x3	36	
1600	1620		1624		1820	1930	56*	56	M52x3	40	
1800	1820		1824		2020	2130	58*	56	M52x3	44	
2000	2020		2024		2230	2345	60*	62	M56x3	48	

N.B. Le dimensioni delle flange segnate con asterisco non sono previste dalle norme UNI 2278
I dati sono desunti dalle norme UNI 2223

* Lo spessore è indicativo

Flange piane da saldare a sovrapposizione



UNI 6083-67 PN.25

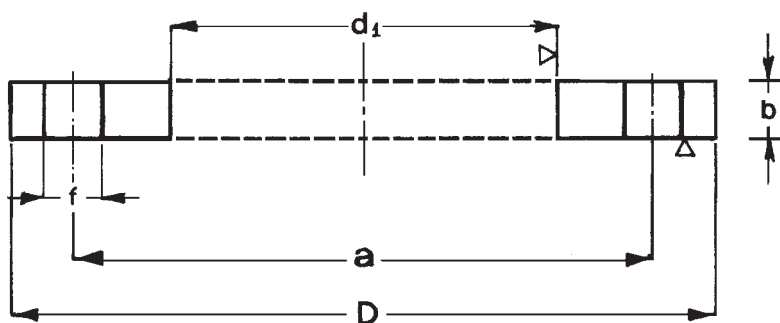

DN	Ø TUBO		d ₁		a	D	b	f	VITI	N. FORI	Kg.
	DIN	ISO	DIN	ISO							
10	13,5	17,2	14,0	17,5	60	90	14	14	M12	4	0,60
15	20,0	21,3	20,5	22,0	65	95	14	14	M12	4	0,67
20	25,0	26,9	25,5	27,5	75	105	16	14	M12	4	0,94
25	30,0	33,7	30,5	34,0	85	115	16	14	M12	4	1,11
32	38,0	42,4	38,5	43,0	100	140	18	18	M16	4	1,83
40	44,5	48,3	45,0	49,0	110	150	18	18	M16	4	2,09
50	57,0	60,3	58,0	61,5	125	165	20	18	M16	4	2,73
65	76,1		77,0		145	185	24	18	M16	8	3,80
80	88,9		90,0		160	200	26	18	M16	8	4,70
100	108,0	114,3	109,0	115,5	190	235	26	22	M20	8	6,09
125	133,0	139,7	134,5	141,0	220	270	28	25	M22	8	8,22
150	159,0	168,3	160,5	170,0	250	300	30	25	M22	8	10,30
200	219,1		221,0		310	360	32	25	M22	12	14,30
250	267,0	273,0	269,0	275,0	370	425	36	30	M27	12	20,90
300	323,9		326,0		430	485	40	30	M27	16	28,30
350	368,0	355,6	370,5	358,0	490	555	44	33	M30	16	44,10
400	419,0	406,4	422,0	409,0	550	620	48	36	M33	16	58,10
450	457,0		460,0		600	670	50*	36	M33	20	
500	508,0		511,0		660	730	52*	36	M33	20	
600	609,6		612,6		770	845	54*	39	M36x3	20	
700	711,2		714,2		875	960	56*	42	M39x3	24	
800	812,8		815,8		990	1085	58*	48	M45x3	24	
900	914,4		917,4		1090	1185	60*	48	M45x3	28	
1000	1016,0		1019,0		1210	1320	64*	56	M52x3	28	

N.B. Le dimensioni delle flange segnate con asterisco non sono previste dalle norme UNI 6083
I dati sono desunti dalle norme UNI 2223

* Lo spessore è indicativo

Flange piane da saldare a sovrapposizione

UNI 6084-67 PN.40

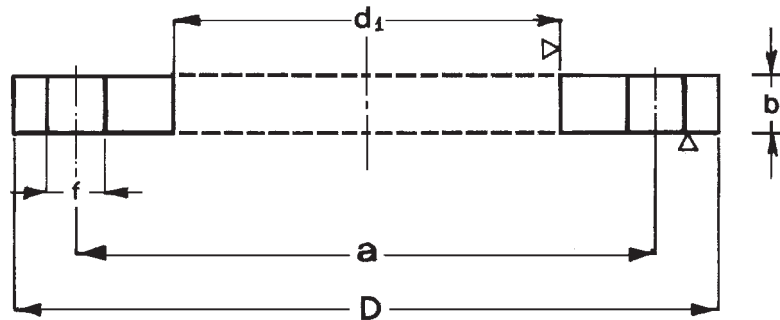

DN	Ø TUBO		d ₁		a	D	b	f	VITI	N. FORI	Kg.
	DIN	ISO	DIN	ISO							
10	13,5	17,2	14,0	17,5	60	90	14	14	M12	4	0,60
15	20,0	21,3	20,5	22,0	65	95	14	14	M12	4	0,67
20	25,0	26,9	25,5	27,5	75	105	16	14	M12	4	0,94
25	30,0	33,7	30,5	34,0	85	115	16	14	M12	4	1,11
32	38,0	42,4	38,5	43,0	100	140	18	18	M16	4	1,83
40	44,5	48,3	45,0	49,0	110	150	18	18	M16	4	2,09
50	57,0	60,3	58,0	61,5	125	165	20	18	M16	4	2,73
65	76,1		77,0		145	185	24	18	M16	8	3,80
80	88,9		90,0		160	200	26	18	M16	8	4,70
100	108,0	114,3	109,0	115,5	190	235	26	22	M20	8	6,09
125	133,0	139,7	134,5	141,0	220	270	28	25	M22	8	8,22
150	159,0	168,3	160,5	170,0	250	300	30	25	M22	8	10,30
200	219,1		221,0		320	375	36	30	M27	12	18,00
250	267,0	273,0	269,0	275,0	385	450	44	33	M30	12	30,90
300	323,9		326,0		450	515	48	33	M30	16	41,90
350	368,0	355,6	370,5	358,0	510	580	54	36	M33	16	62,40
400	419,0	406,4	422,0	409,0	585	660	60	39	M36x3	16	90,30
450	457,2		460,2		610	685	66*	39	M36x3	20	
500	508,0		511,0		670	755	68*	42	M39x3	20	
600	609,6		612,6		795	890	70*	48	M45x3	20	
700	711,2		715,0		900	995	73*	48	M45x3	24	

N.B. Le dimensioni delle flange segnate con asterisco non sono previste dalle norme UNI 6084
I dati sono desunti dalle norme UNI 2223

* Lo spessore è indicativo

Flange a collarino a saldare di testa



UNI 2280-67 PN. 6

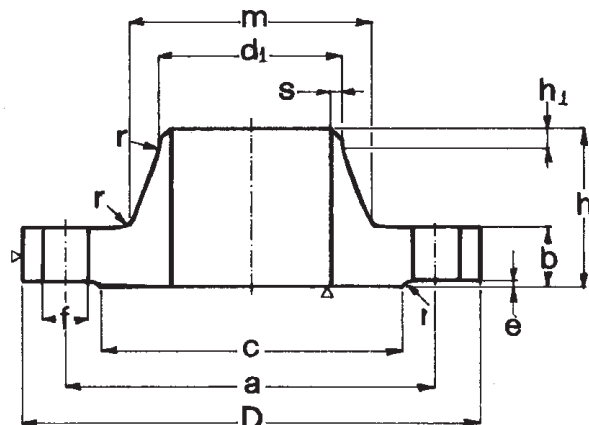

DN	Ø TUBO		d ₁		D	a	m		c	h	b	h ₁	e	r	s	f	VITI	N. FORI	Kg.
	DIN	ISO	DIN	ISO			DIN	ISO											
10	13,5	17,2	14,5	18,0	75	50	22	26	35	28	12	6	2	4	2,3	11	M10	4	0,39
15	20,0	21,3	21,0	22,5	80	55	28	30	40	30	12	6	2	4	2,5	11	M10	4	0,45
20	25,0	26,9	26,0	28,0	90	65	35	38	50	32	14	6	2	4	2,5	11	M10	4	0,66
25	30,0	33,7	31,0	34,5	100	75	40	42	60	35	14	6	2	4	2,8	11	M10	4	0,82
32	38,0	42,4	39,0	43,5	120	90	50	55	70	35	14	6	2	6	3,0	14	M12	4	1,16
40	44,5	48,3	45,5	49,5	130	100	58	62	80	38	14	7	3	6	3,0	14	M12	4	1,38
50	57,0	60,3	58,0	61,5	140	110	70	74	90	38	14	8	3	6	3,5	14	M12	4	1,56
65	76,1		77,0		160	130		88	110	38	14	9	3	6	3,5	14	M12	4	1,95
80	88,9		90,0		190	150		102	128	42	16	10	3	8	3,7	18	M16	4	3,07
100	108,0	114,3	109,0	115,5	210	170	122	130	148	45	16	10	3	8	3,7	18	M16	4	3,56
125	133,0	139,7	134,0	141,0	240	200	148	155	178	48	18	10	3	8	4,0	18	M16	8	4,80
150	159,0	168,3	161,0	170,5	265	225	172	184	202	48	18	12	3	10	5,0	18	M16	8	5,52
200	219,1		221,0		320	280		236	258	55	20	15	3	10	5,0	18	M16	8	8,16
250	267,0	273,0	269,0	275,0	375	335	282	290	312	60	22	15	3	12	5,5	18	M16	12	11,1
300	323,9		326,0		440	395		342	365	62	22	15	4	12	6,0	22	M20	12	14,8
350	368,0	355,6	370,0	357,5	490	445		385	415	62	22	15	4	12	6,5	22	M20	12	19,5
400	419,0	406,4	421,0	408,5	540	495		438	465	65	22	15	4	12	7,0	22	M20	16	22,5
450	457,2		459,0		595	550		476	520	65	22	15	4	12	7,3	22	M20	16	25,0
500	508,0		510,0		645	600		538	570	68	24	15	4	12	7,3	22	M20	20	30,4
600	609,6		611,5		755	705		640	670	70	24	16	5	12	7,3	25	M22	20	38,0
700	711,2		715,0		860	810		740	775	70	24	16	5	12	9,0	25	M22	24	45,9
800	812,8		817,0		975	920		842	880	70	24	16	5	12	9,0	30	M27	24	55,0
900	914,4		918,0		1075	1020		942	980	70	26	16	5	12	9,0	30	M27	24	64,7
1000	1016,0		1020,0		1175	1120		1045	1080	70	26	16	5	16	9,0	30	M27	28	70,6
1200	1220,0		1224,0		1405	1340		1248	1295	90	28	20	5	16	9,0	33	M30	32	108,0
1400	1420,0		1424,0		1630	1560		1452	1510	90	32	20	5	16	9,0	36	M33	36	153,0
1600	1620,0		1624,0		1830	1760		1655	1710	90	34	20	5	16	11,0	36	M33	40	189,0
1800	1820,0		1824,0		2045	1970		1855	1920	100	36	20	5	16	11,0	39	M36x3	44	239,0
2000	2020,0		2024,0		2265	2180		2058	2125	110	38	25	5	16	12,0	42	M39x3	48	308,0

Flange a collarino a saldare di testa



UNI 2281-67 PN. 10

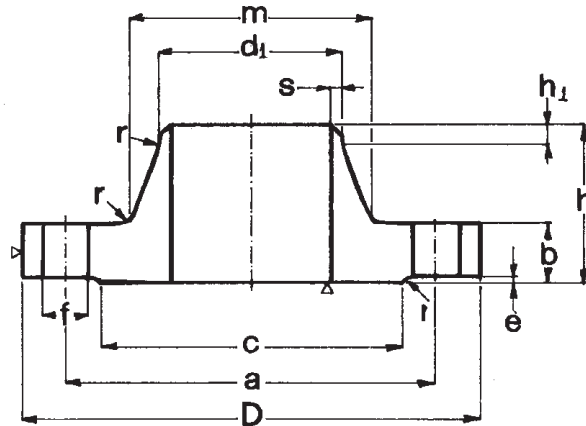

DN	Ø TUBO		d ₁		D	a	m		c	h	b	h ₁	e	r	s	f	VITI	N. FORI	Kg.
	DIN	ISO	DIN	ISO			DIN	ISO											
10	13,5	17,2	14,5	18,0	90	60	25	28	40	35	14	6	2	4	2,3	14	M12	4	0,65
15	20,0	21,3	21,0	22,5	95	65	30	32	45	35	14	6	2	4	2,5	14	M12	4	0,73
20	25,0	26,9	26,0	28,0	105	75	38	40	58	38	16	6	2	4	2,5	14	M12	4	1,03
25	30,0	33,7	31,0	34,5	115	85	42	45	68	38	16	6	2	4	2,8	14	M12	4	1,23
32	38,0	42,4	39,0	43,5	140	100	52	56	78	40	16	6	2	6	3,0	18	M16	4	1,80
40	44,5	48,3	45,5	49,5	150	110	60	64	88	42	16	7	3	6	3,0	18	M16	4	2,08
50	57,0	60,3	58,0	61,5	165	125	72	75	102	45	18	8	3	6	3,5	18	M16	4	2,78
65	76,1		77,0		185	145	90		122	45	18	10	3	6	3,5	18	M16	4	3,40
80	88,9		90,0		200	160	105		138	50	20	10	3	8	3,7	18	M16	4	4,20
100	108,0	114,3	109,0	115,5	220	180	125	131	158	52	20	12	3	8	3,7	18	M16	8	4,75
125	133,0	139,7	134,0	141,0	250	210	150	156	188	55	22	12	3	8	4,0	18	M16	8	6,45
150	159,0	168,3	161,0	170,5	285	240	175	184	212	55	22	12	3	10	5,0	22	M20	8	8,00
200	219,1		221,0		340	295	235		268	62	24	16	3	10	5,0	22	M20	8	11,4
250	267,0	273,0	269,0	275,0	395	350	285	292	320	68	26	16	3	12	5,5	22	M20	12	15,2
300	323,9		326,0		445	400	344		370	68	26	16	4	12	6,0	22	M20	12	18,0
350	368,0	355,6	370,0	357,5	505	460	385		430	68	26	16	4	12	6,4	22	M20	16	24,5
400	419,0	406,4	421,0	408,5	565	515	440		482	72	26	16	4	12	7,0	25	M22	16	30,2
450	457,2		459,0		615	565	478		532	72	26	16	4	12	7,3	25	M22	20	32,3
500	508,0		510,0		670	620	542		585	75	28	16	4	12	7,3	25	M22	20	40,4
600	609,6		611,5		780	725	642		685	80	28	18	5	12	7,3	30	M27	20	50,0
700	711,3		715,0		895	840	745		800	80	30	18	5	12	9,0	30	M27	24	66,4
800	812,8		817,0		1015	950	850		905	90	32	18	5	12	9,0	33	M30	24	89,3
900	914,4		918,0		1115	1050	950		1005	95	34	20	5	12	9,0	33	M30	28	104
1000	1016,0		1020,0		1230	1160	1052		1110	95	34	20	5	16	9,0	36	M33	28	121
1200	1220,0		1224,0		1455	1380	1255		1330	115	38	25	5	16	10,0	39	M36x3	32	180
1400	1420,0		1424,0		1675	1590	1460		1535	120	42	25	5	16	11,0	42	M39x3	36	248
1600	1620,0		1624,0		1915	1820	1665		1760	130	46	25	5	16	12,0	48	M45x3	40	352
1800	1820,0		1824,0		2115	2020	1868		1960	140	50	30	5	16	13,0	48	M45x3	44	433
2000	2020,0		2024,0		2325	2230	2072		2170	150	54	30	5	16	14,0	48	M45x3	48	543

Flange a collarino a saldare di testa



UNI 2282-67 PN. 16

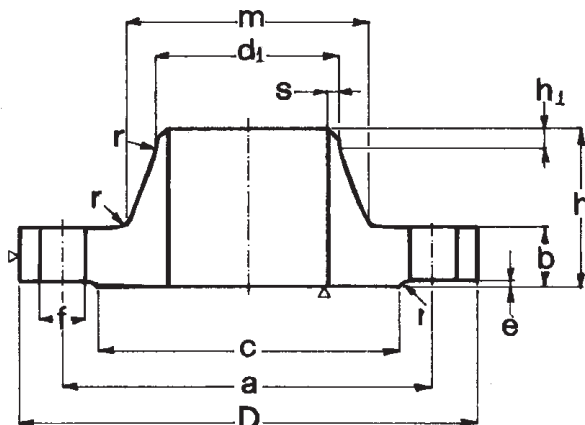

DN	Ø TUBO		d ₁		D	a	m		c	h	b	h ₁	e	r	s	f	VITI	N. FORI	Kg.
	DIN	ISODIN	ISO	ISO			DIN	ISO											
10	13,5	17,2	14,5	18,0	90	60	25	28	40	35	14	6	2	4	2,3	14	M12	4	0,65
15	20,0	21,3	21,0	22,5	95	65	30	32	45	35	14	6	2	4	2,5	14	M12	4	0,73
20	25,0	26,9	26,0	28,0	105	75	38	40	58	38	16	6	2	4	2,5	14	M12	4	1,03
25	30,0	33,7	31,0	34,5	115	85	42	45	68	38	16	6	2	4	2,8	14	M12	4	1,23
32	38,0	42,4	39,0	43,5	140	100	52	56	78	40	16	6	2	6	3	18	M16	4	1,80
40	44,5	48,3	45,5	49,5	150	110	60	64	88	42	16	7	3	6	3	18	M16	4	2,08
50	57,0	60,3	58,0	61,5	165	125	72	75	102	45	18	8	3	6	3,5	18	M16	4	2,78
65	76,1	77,0	77,0	77,0	185	145	90	90	122	45	18	10	3	6	3,5	18	M16	4	3,40
80	88,9	90,0	90,0	90,0	200	160	105	105	138	50	20	10	3	8	3,7	18	M16	8	4,20
100	108,0	114,3	109,0	115,5	220	180	125	131	158	52	20	12	3	8	3,7	18	M16	8	4,75
125	133,0	139,7	134,0	141,0	250	210	150	156	188	55	22	12	3	8	4	18	M16	8	6,45
150	159,0	168,3	161,0	170,5	285	240	175	184	212	55	22	12	3	10	5	22	M20	8	8,00
200	219,1	221,0	221,0	221,0	340	295	235	235	268	62	24	16	3	10	5	22	M20	12	11,1
250	267,0	273,0	269,0	275,0	405	355	285	292	320	70	26	16	3	12	5,5	25	M22	12	16,3
300	323,9	326,0	326,0	326,0	460	410	344	344	378	78	28	16	4	12	6	25	M22	12	21,8
350	368,0	355,6	370,0	357,5	520	470	390	390	438	82	30	16	4	12	6,4	25	M22	16	31,7
400	419,0	406,4	421,0	408,5	580	525	445	445	490	85	32	16	4	12	7	30	M27	16	38,3
450	457,2	459,0	459,0	459,0	640	585	485	485	550	85	32	16	4	12	7,3	30	M27	20	45,4
500	508,0	510,0	510,0	510,0	715	650	548	548	610	90	34	16	4	12	7,3	33	M30	20	61,1
600	609,6	611,5	611,5	611,5	840	770	652	652	725	95	36	18	5	12	7,3	36	M33	20	84,6
700	711,3	715,0	715,0	715,0	910	840	755	755	795	100	36	18	5	12	9	36	M33	24	87,4
800	812,8	817,0	817,0	817,0	1025	950	855	855	900	105	38	20	5	12	9	39	M36x3	24	109
900	914,4	918,0	918,0	918,0	1125	1050	955	955	1000	110	40	20	5	12	10	39	M36x3	28	129
1000	1016,0	1020,0	1020,0	1020,0	1255	1170	1058	1058	1115	120	42	22	5	16	12	42	M39x3	28	175
1200	1220,0	1224,0	1224,0	1224,0	1485	1390	1262	1262	1330	130	48	30	5	16	14	48	M45x3	32	257
1400	1420,0	1424,0	1424,0	1424,0	1685	1590	1465	1465	1530	145	52	30	5	16	16	48	M45x3	36	337
1600	1620,0	1624,0	1624,0	1624,0	1930	1820	1668	1668	1750	160	58	35	5	16	17	56	M52x3	40	481
1800	1820,0	1824,0	1824,0	1824,0	2130	2020	1870	1870	1950	170	62	35	5	16	19	56	M52x3	44	591
2000	2020,0	2024,0	2024,0	2024,0	2345	2230	2072	2072	2150	180	66	40	5	16	21	62	M56x3	48	727

Flange a collarino a saldare di testa



UNI 2283-67 PN. 25

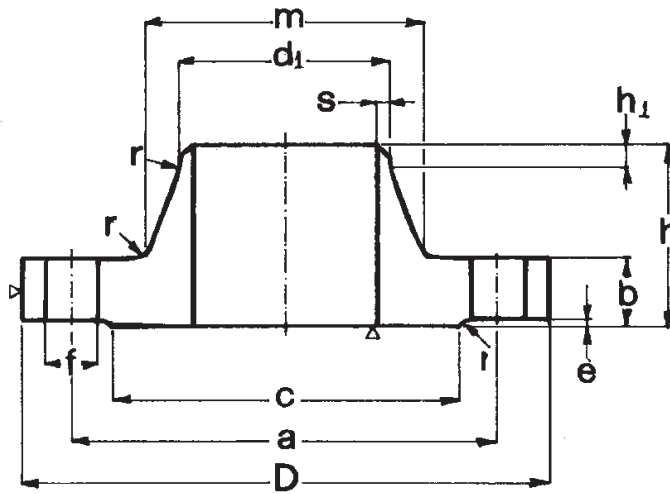

DN	Ø TUBO		d ₁		D	a	m		c	h	b	h ₁	e	r	s	f	VITI	N. FORI	Kg.
	DIN	ISODIN	ISO	ISO			DIN	ISO											
10	13,5	17,2	14,5	18,0	90	60	25	28	40	35	16	6	2	4	2,3	14	M12	4	0,74
15	20,0	21,3	21,0	22,5	95	65	30	32	45	38	16	6	2	4	2,5	14	M12	4	0,83
20	25,0	26,9	26,0	28,0	105	75	38	40	58	40	18	6	2	4	2,5	14	M12	4	1,15
25	30,0	33,7	31,0	34,5	115	85	42	46	68	40	18	6	2	4	2,8	14	M12	4	1,38
32	38,0	42,4	39,0	43,5	140	100	52	56	78	42	18	6	2	6	3	18	M16	4	2,01
40	44,5	48,3	45,5	49,5	150	110	60	64	88	45	18	7	3	6	3	18	M16	4	2,33
50	57,0	60,3	58,0	61,5	165	125	72	75	102	48	20	8	3	6	3,5	18	M16	4	3,08
65	76,0		77,0		185	145	90		122	52	22	10	3	6	3,5	18	M16	8	3,95
80	88,9		90,0		200	160	105		138	58	24	12	3	8	3,7	18	M16	8	4,98
100	108,0	114,3	109,0	115,5	235	190	128	134	162	65	24	12	3	8	3,7	22	M20	8	6,70
125	133,0	139,7	134,0	141,0	270	220	155	162	188	68	26	12	3	8	4	25	M22	8	9,20
150	159,0	168,3	161,0	170,5	300	250	182	192	218	75	28	12	3	10	5	25	M22	8	12,0
200	219,1		221,0		360	310	244		278	80	30	16	3	10	5	25	M22	12	16,8
250	267,0	273,0	269,0	275,0	425	370	292	298	355	88	32	18	3	12	5,5	30	M27	12	23,3
300	323,9		326,0		485	430	352		390	92	34	18	4	12	6	30	M27	16	30,5
350	368,0	355,6	370,0	357,5	555	490	398		450	100	38	20	4	12	6,4	33	M30	16	47,6
400	419,0	406,4	421,0	408,5	620	550	452		505	110	40	20	4	12	7,3	36	M33	16	62,1
450	457,2		459,0		670	600	492		555	115	40	20	4	12	8	36	M33	20	67,8
500	508,0		510,0		730	660	558		615	125	44	20	4	12	8	36	M33	20	88,8
600	609,6		611,5		845	770	660		720	125	46	20	5	12	8	39	M36x3	20	114
700	711,2		715,0		960	875	760		820	125	46	20	5	12	10	42	M39x3	24	138
800	812,8		817,0		1085	990	865		930	135	50	22	5	12	11	48	M45x3	24	185
900	914,4		918,0		1185	1090	968		1030	145	54	24	5	12	12	48	M45x3	28	224
1000	1016,0		1020,0		1320	1210	1070		1140	155	58	24	5	16	13	56	M52x3	28	293

Flange a collarino a saldare in testa



UNI 2284-67 PN. 40

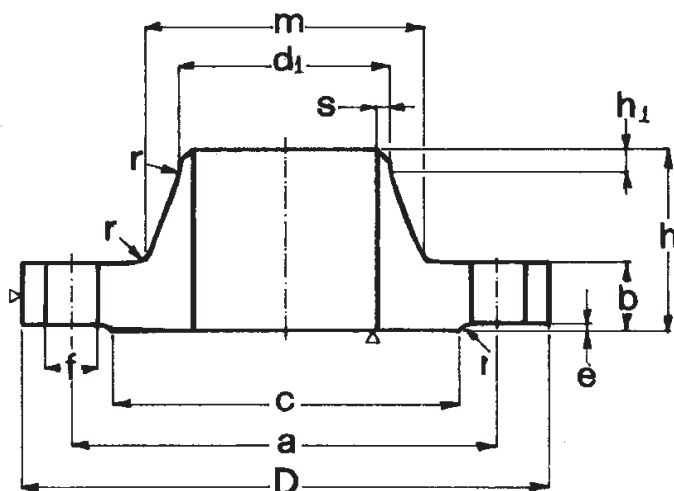

DN	Ø TUBO		d ₁		D	a	m		c	h	b	h ₁	e	r	s	f	VITI	N. FORI	Kg.
	DIN	ISODIN	ISO	ISO			DIN	ISO											
10	13,5	17,2	14,5	18,0	90	60	25	28	40	35	16	6	2	4	2,3	14	M12	4	0,74
15	20,0	21,3	21,0	22,5	95	65	30	32	45	38	16	6	2	4	2,5	14	M12	4	0,83
20	25,0	26,9	26,0	28,0	105	75	38	40	58	40	18	6	2	4	2,5	14	M12	4	1,15
25	30,0	33,7	31,0	34,5	115	85	42	46	68	40	18	6	2	4	2,8	14	M12	4	1,38
32	38,0	42,4	39,0	43,5	140	100	52	56	78	42	18	6	2	6	3	18	M16	4	2,01
40	44,5	48,3	45,5	49,5	150	110	60	64	88	45	18	7	3	6	3	18	M16	4	2,33
50	57,0	60,3	58,0	61,5	165	125	72	75	102	48	20	8	3	6	3,5	18	M16	4	3,08
65	76,0		77,0		185	145	90		122	52	22	10	3	6	3,5	18	M16	8	3,95
80	88,9				200	160	105		138	58	24	12	3	8	3,7	18	M16	8	4,98
100	108,0	114,3	109,0	115,5	235	190	128	134	162	65	24	12	3	8	3,7	22	M20	8	6,70
125	133,0	139,0	134,0	141,0	270	220	155	162	188	68	26	12	3	8	4	25	M22	8	9,20
150	159,0	168,3	161,0	170,5	300	250	182	192	218	75	28	12	3	10	5	25	M22	8	12,0
200	219,1		221,0		375	320	244		285	88	34	16	3	10	5,5	30	M27	12	20,8
250	267,0	273,0	269,0	275,0	450	385	298	306	345	105	38	18	3	12	6,5	33	M30	12	33,8
300	323,9		326,0		515	450	362		410	115	42	18	4	12	7,3	33	M30	16	47,4
350	368,0	355,6	370,0	357,5	580	510	408		465	125	46	20	4	12	8	36	M33	16	69,0
400	419,0	406,4	421,0	408,5	660	585	462		535	135	50	20	4	12	9	39	M36x3	16	96,0
450	457,2		459,0		685	610	500		560	135	50	20	4	12	9	39	M36x3	20	91,6
500	508,0		510,0		755	670	562		615	140	52	20	4	12	10	42	M39x3	20	117
600	609,6		611,5		890	795	666		735	145	54	20	5	12	18	48	M45x3	20	145
700	711,2		715,0		995	900	768		840	145	58	20	5	12	18	48	M45x3	24	190
800	812,8		817,0		1140	1030	875		960	150	60	22	5	12	20	56	M52x3	24	260
900	914,4		918,0		1250	1140	980		1070	155	64	24	5	12	22	56	M52x3	28	336
1000	1016		1020		1360	1250	1090		1180	165	68	24	5	16	25	56	M52x3	28	440

Flange a collarino a saldare di testa

UNI 2285-67 PN. 64

UNI 2286-67 PN. 100

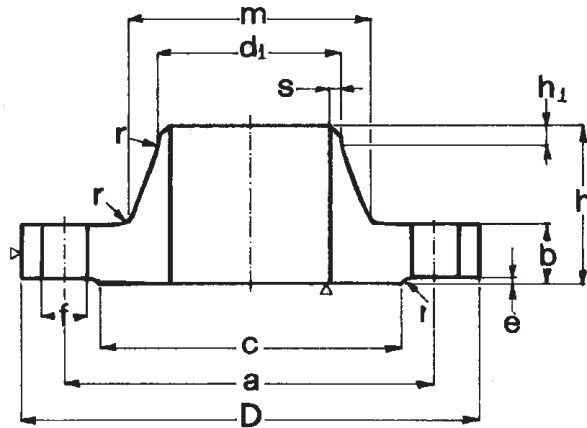

DN	Ø TUBO		d ₁		D	a	m		c	h	b	h ₁	e	r	s	f	VITI	N. FORI	Kg.
	DIN	ISO	DIN	ISO			DIN	ISO											

UNI 2285-67 PN. 64

DAL DN 10 AL DN 40 USARE FLANGE PN. 100 - UNI 2286-67

50	57	60,3	58	61,5	180	135	78	82	95	62	26	10	3	6	3,5	22	M20	4	4,45
65	76		77		205	160	98		120	68	26	12	3	6	3,5	22	M20	8	5,50
80	88,9		90		215	170	112		130	72	28	12	3	8	3,7	22	M20	8	6,43
100	108	114,3	109	115,5	250	200	132	138	160	78	30	12	3	8	4	25	M22	8	9,05
125	133	139,7	134	141	295	240	162	168	185	88	34	12	3	8	5	30	M27	8	14,2
150	159	168,3	161	170,5	345	280	192	202	215	95	36	12	3	10	6	33	M30	8	20,8
200	219,1		221		415	345	256		270	110	42	16	3	10	7,3	36	M33	12	33,2
250	267	273	269	275	470	400	310	316	325	125	46	18	3	12	8	36	M33	12	46,0
300	323,9		326		530	460	372		375	140	52	18	4	12	9,8	36	M33	16	63,9
350	368	355,6	370	357,5	600	525	420		435	150	56	20	4	12	11	39	M36x3	16	93,0
400	419	406,4	421	408,5	670	585	475		485	160	60	20	4	12	12	42	M39x3	16	122,0

UNI 2286-67 PN. 100

10	13,5	17,2	14,5	18	100	70	28	32	40	45	20	6	2	4	2,3	14	M12	4	1,08
15	20	21,3	21	22,5	105	75	32	34	45	45	20	6	2	4	2,5	14	M12	4	1,19
20	25	26,9	26	28	130	90	42	44	58	52	22	8	2	4	2,8	18	M16	4	2,02
25	30	33,7	31	34,5	140	100	48	52	65	58	24	8	2	4	2,8	18	M16	4	2,60
32	38	42,4	39	43,5	155	110	58	62	75	60	24	8	2	6	3	22	M20	4	3,12
40	44,5	48,3	45,5	49,5	170	125	65	70	85	62	26	10	3	6	3,5	22	M20	4	3,99
50	57	60,3	58	61,5	195	145	86	90	95	68	28	10	3	6	4	25	M22	4	5,75
65	76,1		77		220	170	108		120	76	30	12	3	6	4,5	25	M22	8	7,57
80	88,9		90		230	180	120		130	78	32	12	3	8	5	25	M22	8	8,72
100	108	114,3	109	115,5	265	210	145	150	160	90	36	12	3	8	6	30	M27	8	12,9
125	133	139,7	134	141	315	250	180		185	105	40	12	3	8	6,8	33	M30	8	20,7
150	159	168,3	161	170,5	355	290	210		215	115	44	12	3	10	7	33	M30	12	27,4
200	219,1		221		430	360	278		270	130	52	16	3	10	9,8	36	M33	12	48,7
250	267	273	269	275	505	430	340		325	157	60	18	3	12	12	39	M36	12	78,8
300	323,9		326		585	500	400		375	170	68	18	4	12	13,5	42	M39x3	16	114
350	368	355,6	370	357,5	655	560	460		435	189	74	20	4	12	15,2	48	M45x3	16	163
400	419	406,4	421	408,5	715	620	520		485	200	80	20	4	12	18	48	M45x3	16	220

Flange a collarino a saldare di testa

UNI 6085-67 PN. 160

UNI 6086-67 PN. 250

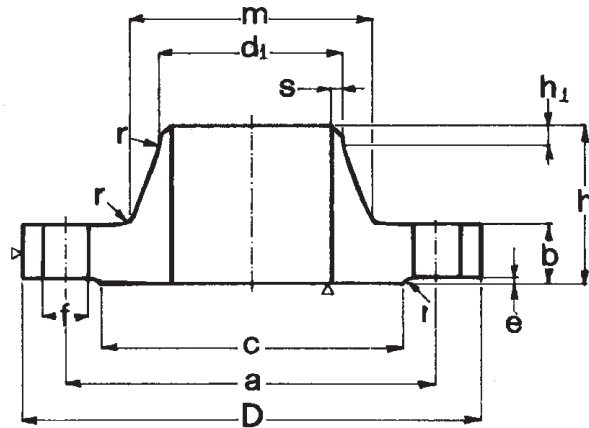

DN	Ø TUBO		d ₁		D	a	m		c	h	b	h ₁	e	r	s	f	VITI	N. FORI	Kg.
	DIN	ISO	DIN	ISO			DIN	ISO											

UNI 6085-67 PN. 160

10	13,5	17,2	14,5	18,0	100	70	28	32	40	45	20	6	2	4	2,8	14	M12	4	1,08
15	20,0	21,3	22,5	22,5	105	75	32	34	45	45	20	6	2	4	2,8	14	M12	4	1,19
20	25,0	26,9	26,0	28,0	130	90	42	44	58	52	22	8	2	4	3	18	M16	4	2,03
25	30,0	33,7	31,0	34,5	140	100	48	52	65	58	24	8	2	4	3,7	18	M16	4	2,67
32	38,0	42,4	39,0	43,5	155	110	58	62	75	62	26	10	2	4	4	22	M20	4	3,42
40	44,5	48,3	45,5	49,1	170	125	65	70	85	64	28	10	3	6	4,5	22	M20	4	4,37
50	57,0	60,3	58,0	61,5	195	145	86	90	95	75	30	10	3	6	5	25	M22	4	6,34
65	76,1		77		220	170		108	120	82	34	12	3	6	6	25	M22	8	8,82
80	88,9		90		230	180		120	130	86	36	12	3	8	6,8	25	M22	8	10,2
100	108,0	114,3	109,0	115,5	265	210	145	150	160	100	40	12	3	8	8,5	30	M27	8	15,1
125	133,0	139,7	134,0	141,0	315	250		180	185	115	44	14	3	8	9,3	33	M30	8	23,7
150	159,0	168,3	161,0	170,5	355	290		210	215	128	50	14	3	10	12	33	M30	12	33,5
200	219,1		221		430	360		278	280	140	60	16	3	10	15,2	36	M33	12	59,0
250	267,0	273,0	269,0	275,0	515	430		340	325	155	68	18	3	12	17	42	M39x3	12	93,0
300	323,9		326		585	500		400	375	175	78	18	4	12	21	42	M39x3	16	136

UNI 6086-67 PN. 250

10	13,5	17,2	14,5	18,0	125	85		42	40	58	24	6	2	4	3	18	M16	4	2,08
15	20,0	21,3	21,0	22,5	130	90		48	45	60	26	6	2	4	3,5	18	M16	4	2,48
20	25,0	26,9	26,0	28,0	135	95		55	58	62	26	8	2	4	4	18	M16	4	2,74
25	30,0	33,7	31,0	34,5	150	105		60	65	65	28	8	2	4	4,5	22	M20	4	3,55
32	38,0	42,4	39,0	43,5	165	120		74	75	75	32	10	2	4	5,5	22	M20	4	5,09
40	44,5	48,3	45,5	49,5	185	135		84	85	80	34	10	3	6	6	25	M22	4	6,66
50	57,0	60,3	58,0	61,5	200	150		95	95	85	38	10	3	6	6,8	25	M22	8	8,18
65	76,1		77		230	180		124	120	95	42	12	3	6	8,5	25	M22	8	12,7
80	88,9		90		255	200		136	130	102	46	12	3	8	9,3	30	M27	8	16,5
100	108,0	114,3	109,0	115,5	300	235		164	160	120	54	14	3	8	11,5	33	M30	8	27,2
125	133,0	139,0	134,0	141,0	340	275		200	185	140	60	16	3	8	14,7	33	M30	12	39,5
150	159,0	168,3	161,0	170,5	390	320		240	215	160	68	18	3	10	17	36	M33	12	59,8
200	219,1		221		485	400		305	300	190	82	25	3	10	21	42	M39x3	12	112
250	267,0	273,0	269,0	275,0	585	490		385	350	215	100	30	3	12	26	48	M45x3	16	190

Flange cieche

UNI 6091-67 PN. 6

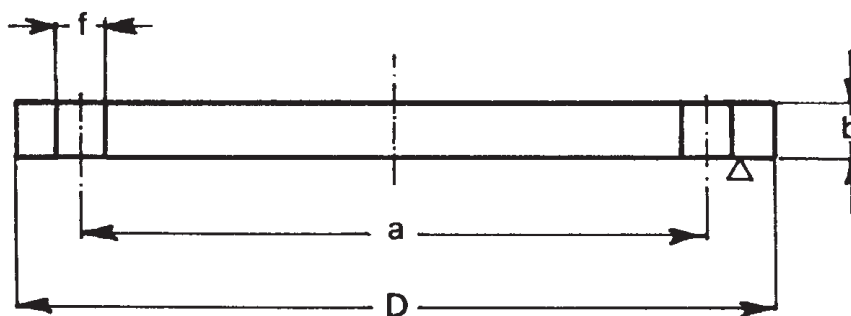

DN	a	D	b	f	VITI	N. FORI	Kg.
10	50	75	12	11	M10	4	0,38
15	55	80	12	11	M10	4	0,44
20	65	90	14	11	M10	4	0,65
25	75	100	14	11	M10	4	0,82
32	90	120	14	14	M12	4	1,17
40	100	130	14	14	M12	4	1,39
50	110	140	14	14	M12	4	1,62
65	130	160	14	14	M12	4	2,14
80	150	190	16	18	M16	4	3,43
100	170	210	16	18	M16	4	4,22
125	200	240	18	18	M16	8	6,11
150	225	265	18	18	M16	8	7,51
200	280	320	20	18	M16	8	12,3
250	335	375	22	18	M16	12	18,5
300	395	440	22	22	M20	12	25,5
350	445	490	22	22	M20	12	31,8
400	495	540	22	22	M20	16	38,5
450	550	595	22	22	M20	16	47,0
500	600	645	24	22	M20	20	60,4
600	705	755	26*	25	M22	20	93,0
700	810	860	28*	25	M22	24	130
800	920	975	28*	30	M27	24	164
900	1020	1075	30*	30	M27	24	215
1000	1120	1175	30*	30	M27	28	257
1200	1340	1405	32*	33	M30	32	393
1400	1560	1630	34*	36	M33	36	560
1600	1760	1830	34*	36	M33	40	705
1800	1970	2045	36*	39	M36x3	44	930
2000	2180	2265	38*	42	M39x3	48	1200

N.B. Le dimensioni delle flange segnate con asterisco non sono previste dalle norme UNI 6091
I dati sono desunti dalle norme UNI 2223

* Lo spessore è indicativo

Flange cieche

UNI 6092-67 PN. 10

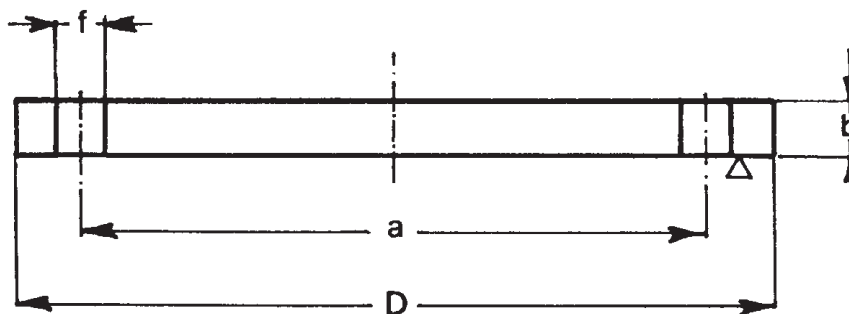

DN	a	D	b	f	VITI	N. FORI	Kg.
10	60	90	14	14	M12	4	0,63
15	65	95	14	14	M12	4	0,71
20	75	105	16	14	M12	4	1,01
25	85	115	16	14	M12	4	1,22
32	100	140	16	18	M16	4	1,80
40	110	150	16	18	M16	4	2,09
50	125	165	18	18	M16	4	2,87
65	145	185	18	18	M16	4	3,65
80	160	200	20	18	M16	4	4,61
100	180	220	20	18	M16	8	5,65
125	210	250	22	18	M16	8	8,12
150	240	285	22	22	M20	8	10,5
200	295	340	24	22	M20	8	16,50
250	350	395	26	22	M20	12	24,1
300	400	445	26	22	M20	12	30,8
350	460	505	26	22	M20	16	39,6
400	515	565	26	25	M22	16	49,6
450	565	615	26	25	M22	20	58,6
500	620	670	28	25	M22	20	75,3
600	725	780	28*	30	M27	20	106
700	840	895	30*	30	M27	24	148
800	950	1015	32*	33	M30	24	203
900	1050	1115	32*	33	M30	28	248
1000	1160	1230	34*	36	M33	28	320
1200	1380	1455	36*	39	M36x3	32	475
1400	1590	1675	38*	42	M39x3	36	662
1600	1820	1915	38*	48	M45x3	40	860
1800	2020	2115	40*	48	M45x3	44	1115
2000	2230	2325	42*	48	M45x3	48	1360

N.B. Le dimensioni delle flange segnate con asterisco non sono previste dalle norme UNI 6092
I dati sono desunti dalle norme UNI 2223

* Lo spessore è indicativo

Flange cieche

UNI 6093-67 PN. 16

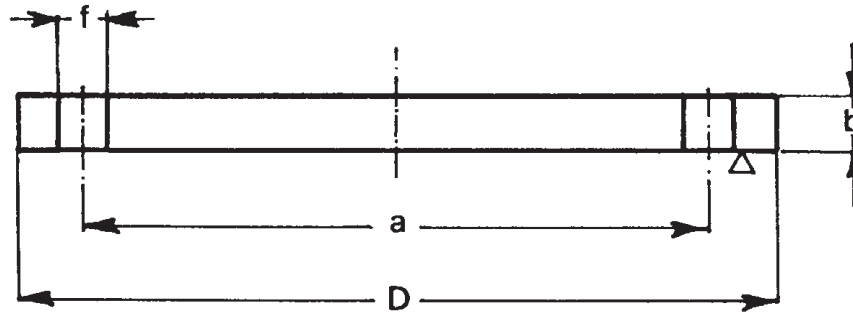

DN	a	D	b	f	VITI	N. FORI	Kg.
10	60	90	14	14	M12	4	0,63
15	65	95	14	14	M12	4	0,71
20	75	105	16	14	M12	4	1,01
25	85	115	16	14	M12	4	1,22
32	100	140	16	18	M16	4	1,80
40	110	150	16	18	M16	4	2,09
50	125	165	18	18	M16	4	2,87
65	145	185	18	18	M16	4	3,65
80	160	200	20	18	M16	8	4,61
100	180	220	20	18	M16	8	5,65
125	210	250	22	18	M16	8	8,12
150	240	285	22	22	M20	8	10,5
200	295	340	24	22	M20	12	16,2
250	355	405	26	25	M22	12	25,1
300	410	460	28	25	M22	12	35,2
350	470	520	30	25	M22	16	48,2
400	525	580	32	30	M27	16	63,5
450	585	640	32	30	M27	20	77,2
500	650	715	34	33	M30	20	102
600	770	840	36*	36	M33	20	143
700	840	910	38*	36	M33	24	177
800	950	1025	38*	39	M36x3	24	227
900	1050	1125	40*	39	M36x3	28	286
1000	1170	1255	42*	42	M39x3	28	416
1200	1390	1485	44*	48	M45x3	32	611
1400	1590	1685	46*	48	M45x3	36	821
1600	1820	1930	46*	56	M52x3	40	970
1800	2020	2130	48*	56	M52x3	44	1370
2000	2230	2345	50*	62	M56x3	48	1690

N.B. Le dimensioni delle flange segnate con asterisco non sono previste dalle norme UNI 6093
I dati sono desunti dalle norme UNI 2223

* Lo spessore è indicativo

Flange cieche

UNI 6094-67 PN. 25

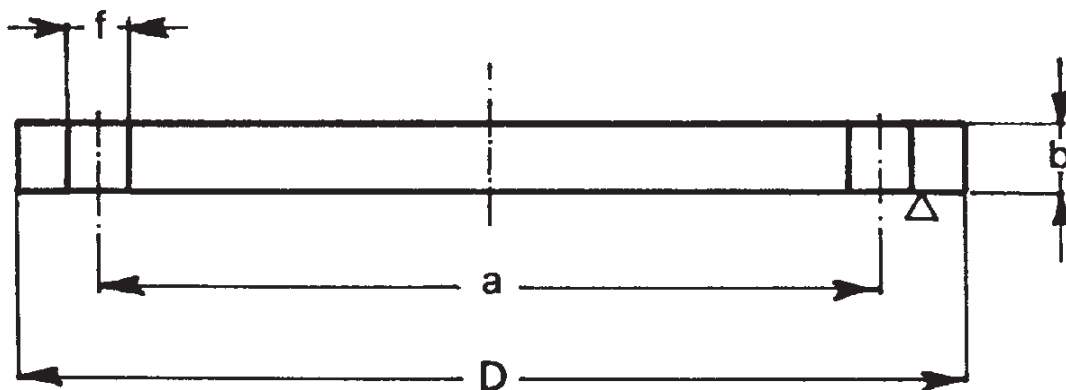

DN	a	D	b	f	VITI	N. FORI	Kg.
10	60	90	16	14	M12	4	0,72
15	65	95	16	14	M12	4	0,81
20	75	105	18	14	M12	4	1,14
25	85	115	18	14	M12	4	1,38
32	100	140	18	18	M16	4	2,03
40	110	150	18	18	M16	4	2,35
50	125	165	20	18	M16	4	3,20
65	145	185	22	18	M16	8	4,29
80	160	200	24	18	M16	8	5,53
100	190	235	24	22	M20	8	7,59
125	220	270	26	25	M22	8	10,8
150	250	300	28	25	M22	8	14,7
200	310	360	30	25	M22	12	22,6
250	370	425	32	30	M27	12	33,5
300	430	485	34	30	M27	16	46,3
350	490	555	38	33	M30	16	68,1
400	550	620	40	36	M33	16	89,7
450	600	670	42	36	M33	20	109
500	660	730	44	36	M33	20	137
600	770	845	46*	39	M36x3	20	206
700	875	960	46*	42	M39x3	24	266
800	990	1085	50*	48	M45x3	24	370
900	1090	1185	54*	48	M45x3	28	477
1000	1210	1320	58*	56	M52x3	28	634

N.B. Le dimensioni delle flange segnate con asterisco non sono previste dalle norme UNI 6094
I dati sono desunti dalle norme UNI 2223

* Lo spessore è indicativo

Flange cieche

UNI 6095-67 PN. 40

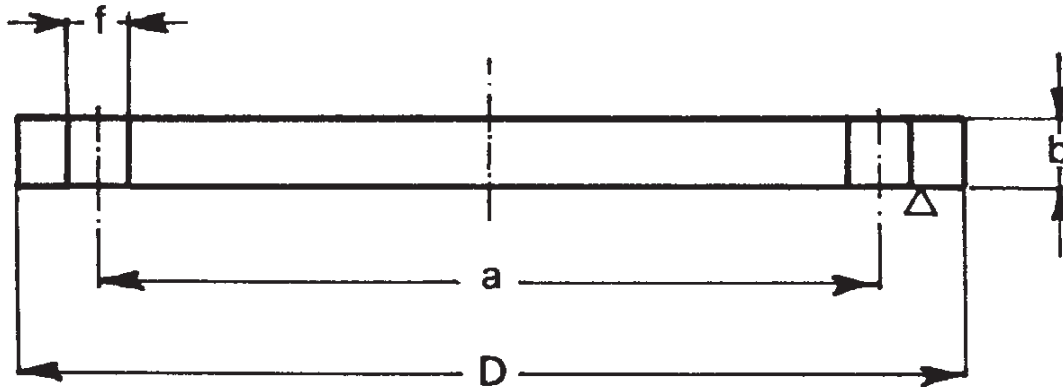

DN	a	D	b	f	VITI	N. FORI	Kg.
10	60	90	16	14	M12	4	0,72
15	65	95	16	14	M12	4	0,81
20	75	105	18	14	M12	4	1,14
25	85	115	18	14	M12	4	1,38
32	100	140	18	18	M16	4	2,03
40	110	150	18	18	M16	4	2,35
50	125	165	20	18	M16	4	3,20
65	145	185	22	18	M16	8	4,29
80	160	200	24	18	M16	8	5,53
100	190	235	24	22	M20	8	7,59
125	220	270	26	25	M22	8	10,8
150	250	300	28	25	M22	8	14,7
200	320	375	34	30	M27	12	27,2
250	385	450	38	33	M30	12	44,4
300	450	515	42	33	M30	16	64,2
350	510	580	46	36	M33	16	89,5
400	585	660	50	39	M36x3	16	127
450	610	685	52	39	M36x3	20	141
500	670	755	52	42	M39x3	20	172
600	795	890	54*	48	M45x3	20	
700	900	995	58*	48	M45x3	24	

N.B. Le dimensioni delle flange segnate con asterisco non sono previste dalle norme UNI 6095
I dati sono desunti dalle norme UNI 2223

* Lo spessore è indicativo

Flange cieche

UNI 6096-67 PN. 64

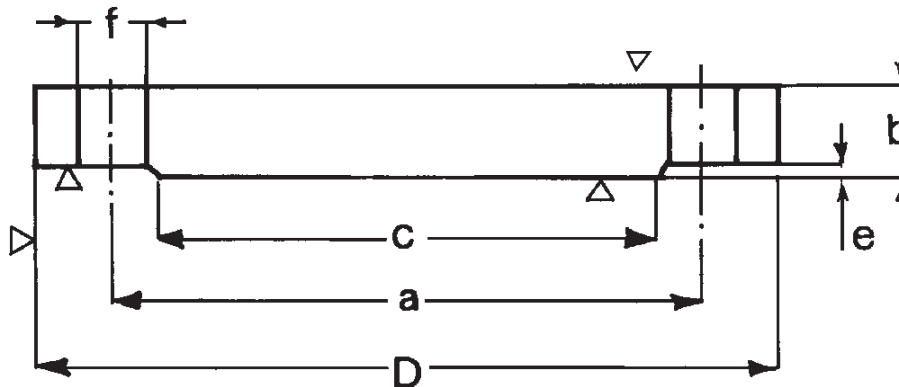

DN	a	D	b	c	f	e	VITI	N. FORI	Kg.
10	70	100	20	40	14	2	M12	4	1,04
15	75	105	20	45	14	2	M12	4	1,16
20	90	130	22	58	18	2	M16	4	1,96
25	100	140	24	65	18	2	M16	4	2,53
32	110	155	24	75	22	2	M20	4	3,06
40	125	170	26	85	22	3	M20	4	3,95
50	135	180	26	95	22	3	M20	4	4,50
65	160	205	26	120	22	3	M20	8	5,68
80	170	215	28	130	22	3	M20	8	6,84
100	200	250	30	160	25	3	M22	8	10,0
125	240	295	34	185	30	3	M27	8	15,9
150	280	345	36	215	33	3	M30	8	23,3
200	345	415	42	270	36	3	M30	12	39,0
250	400	470	46	325	36	3	M33	12	56,4
300	460	530	52	375	36	4	M33	16	80,5
350	525	600	56	435	39	4	M36x3	16	112
400	585	670	60	485	42	4	M39x3	16	151
450	630	715	66*	535	42	4	M39x3	20	212
500	705	800	68*	590	48	4	M45x3	20	273
600	820	930	70*	700	56	5	M52x3	20	380
700	935	1045	73*	810	56	5	M52x3	24	501

N.B. Le dimensioni delle flange segnate con asterisco non sono previste dalle norme UNI 6096
I dati sono desunti dalle norme UNI 2223

* Lo spessore è indicativo

Flange cieche

UNI 6097-67 PN. 100

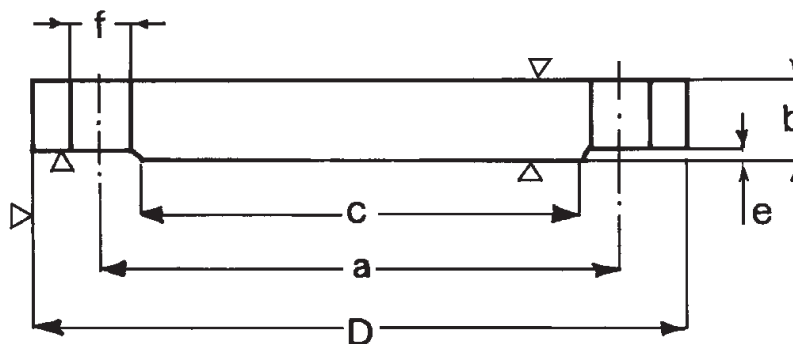

DN	a	D	b	c	f	e	VITI	N. FORI	Kg.
10	70	100	20	40	14	2	M12	4	1,04
15	75	105	20	45	14	2	M12	4	1,16
20	90	130	22	58	18	2	M16	4	1,96
25	100	140	24	65	18	2	M16	4	2,53
32	110	155	24	75	22	2	M20	4	3,06
40	125	170	26	85	22	3	M20	4	3,95
50	145	195	28	95	25	3	M22	4	5,64
65	170	220	30	120	25	3	M22	8	7,50
80	180	230	32	130	25	3	M22	8	8,87
100	210	265	36	160	30	3	M27	8	13,3
125	250	315	40	185	33	3	M30	8	21,3
150	290	355	44	215	33	3	M30	12	29,4
200	360	430	52	270	36	3	M33	12	52,5
250	430	505	60	325	39	3	M36x3	12	85,1
300	500	585	68	375	42	4	M39x3	16	129
350	560	655	74	435	48	4	M45x3	16	175

Flange cieche

UNI 6098-67 PN. 160

UNI 6099-67 PN. 250

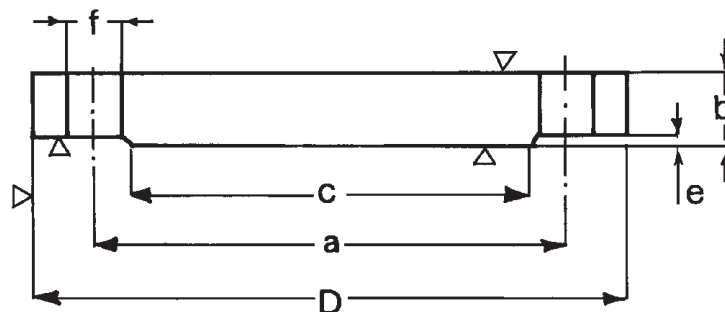

DN	a	D	b	c	f	e	VITI	N. FORI	Kg.
----	---	---	---	---	---	---	------	---------	-----

UNI 6098-67 PN. 160

10	70	100	20	40	14	2	M12	4	1,04
15	75	105	20	45	14	2	M12	4	1,16
20	90	130	22	58	18	2	M16	4	1,96
25	100	140	24	65	18	2	M16	4	2,53
32	110	155	26	75	22	2	M20	4	3,33
40	125	170	28	85	22	3	M20	4	4,28
50	145	195	30	95	25	3	M22	4	6,08
65	170	220	34	120	25	3	M22	8	8,56
80	180	230	36	130	25	3	M22	8	10,5
100	210	265	40	160	30	3	M27	8	14,9
125	250	315	44	185	33	3	M30	8	23,5
150	290	355	50	215	33	3	M30	12	33,6
200	360	430	60	280	36	3	M33	12	61,0
250	430	515	68	325	42	3	M39x3	12	100
300	500	585	78	375	42	4	M39x3	16	147

UNI 6099-67 PN. 250

10	85	125	24	40	18	2	M16	4	1,96
15	90	130	26	45	18	2	M16	4	2,33
20	95	135	26	58	18	2	M16	4	2,55
25	105	150	28	65	22	2	M20	4	3,34
32	120	165	32	75	22	2	M20	4	4,74
40	135	185	34	85	25	3	M22	4	6,20
50	150	200	38	95	25	3	M22	8	7,72
65	180	230	42	120	25	3	M22	8	11,8
80	200	255	46	130	30	3	M27	8	15,6
100	235	300	54	160	33	3	M30	8	26,0
125	275	340	60	185	33	3	M30	12	36,7
150	320	390	68	215	36	3	M33	12	55,6
200	400	485	82	300	42	3	M39x3	12	106
250	490	585	100	350	48	3	M45x3	16	185

Flange libere con collare d'appoggio da saldare di testa UNI 2289-67 PN. 6

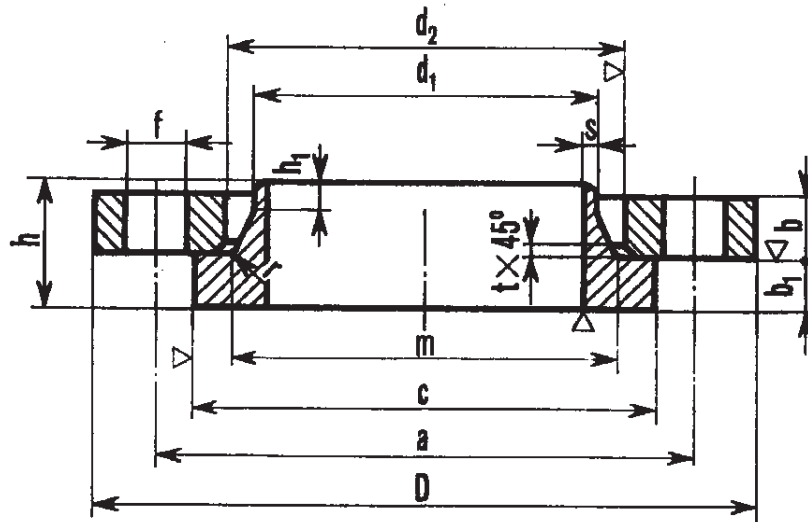

DN	Ø TUBO	FLANGIA							COLLARE							Kg.		
		a	D	b	d ₂	f	t	FORI	b ₁	c	d ₁	h	h ₁	m	r	s	FLANGE	COLLARE
50	60,3	110	140	12	73	14	1,5	4	12	90	61,5	27	6	69	1,5	3,5	0,99	0,48
65	76,1	130	160	12	88	14	2	4	12	110	77,0	27	8	84	2,0	3,5	1,26	0,65
80	88,9	150	190	14	103	18	2	4	14	128	90,0	32	8	99	2,0	3,7	2,09	1,01
100	114,3	170	210	14	128	18	2	4	14	148	115,5	32	8	124	2,0	3,7	2,28	1,13
125	139,7	200	240	14	154	18	2	8	14	178	141,0	32	8	150	2,0	4	2,70	1,53
150	168,3	225	265	14	183	18	2	8	14	202	170,5	33	8,5	204	2,0	5	2,95	1,78
200	219,1	280	320	16	235	18	2	8	16	258	221,0	37	10	231	2,0	5	4,40	2,90
250	273	335	375	20	289	18	2	12	18	312	275,0	44	13	285	2,0	5,5	6,56	4,24
300	323,9	395	440	24	340	22	2	12	18	365	326,0	48	15	336	2,0	6	10,7	5,56
350	355,6	445	490	26	375	22	3	12	18	415	357,5	50	15	370	3,0	6,4	15,0	8,17
400	406,4	495	540	28	425	22	3	16	20	465	408,5	55	15	422	3,0	7	17,5	10,6
450	457,2	550	595	30	480	22	3	16	20	520	459,0	57	15	475	3,0	7,3	21,4	13,0
500	508	600	645	32	530	22	3	20	22	570	510,0	61	15	525	3,0	7,3	24,8	15,5
600	609,6	705	755	36	630	25	3	20	22	670	611,5	65	19	625	3,0	7,3	35,6	18,5
700	711,2	810	860	40	735	25	3	24	24	775	715,0	73	20	730	3,0	9	45,5	26,6
800	812,8	920	975	44	840	30	3	24	24	880	817,0	77	20	835	3,0	9	60,6	32,6
900	914,4	1020	1075	48	940	30	3	24	26	980	918,0	83	25	935	3,0	9	74,1	38,7
1000	1016	1120	1175	52	1045	30	3	28	26	1080	1020,0	87	25	1040	3,0	9	84,4	44,3

Flange libere con collare d'appoggio da saldare in testa

UNI 2290-67 PN. 10 - UNI 2291-67 PN.16

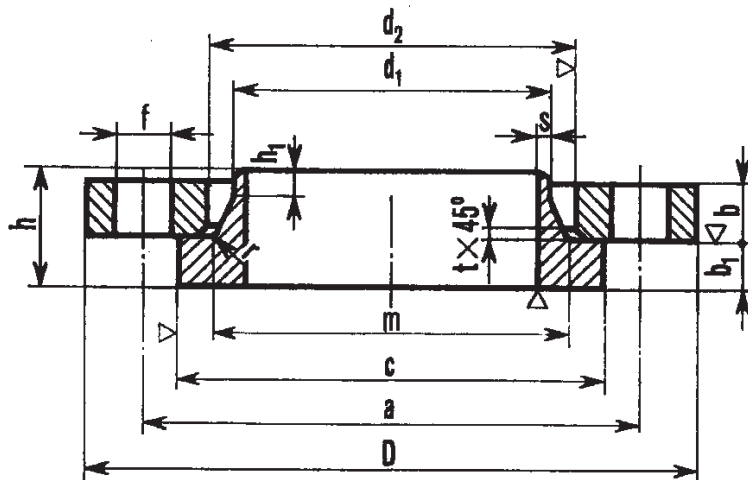

DN	Ø TUBO	FLANGIA							COLLARE							Kg.	
		a	D	b	d ₂	f	t	FORI	b ₁	c	d ₁	h	h ₁	m	r	s	FLANGIA

UNI 2290-67 PN. 10 DAL DN 50 AL DN 150 USARE FLANGE PN. 16 - UNI 2291-67

200	219,1	295	340	20	237	22	3	8	20	268	221	45	11	233	3	5	6,80	4,26
250	273	350	395	22	291	22	3	12	22	320	275	50	12,5	287	3	5,5	8,73	5,78
300	323,9	400	445	26	342	22	3	12	22	370	326	54	18	338	3	6	12,1	7,05
350	355,6	460	505	28	375	22	4	16	22	430	357,5	56	18	370	4	6,4	18,4	11,3
400	406,4	516	565	32	430	25	4	16	24	482	408,5	63	18	425	4	7	24,5	15,0
450	457,2	565	615	34	485	25	4	20	24	532	459	65	18	480	4	7,3	27,4	17,4
500	508	620	670	38	535	25	4	20	26	585	510	71	18	530	4	7,3	35,2	21,3
600	609,6	725	780	44	640	30	4	20	26	685	611,5	77	30	635	4	7,3	49,0	25,5
700	711,2	840	895	50	740	30	5	24	28	800	715	87	34	735	5	9	71,4	38,1
800	812,8	950	1015	56	845	33	5	24	30	905	817	95	38	840	5	9	100	48,2
900	914,4	1050	1115	62	945	33	5	28	32	1005	918	103	44	940	5	9	122	57,2
1000	1016	1160	1230	68	1050	36	5	28	34	1110	1020	111	48	1044	5	9	157	69,5

UNI 2291-67 PN. 16

50	60,3	125	165	16	76	18	2	4	14	102	61,5	33	7	72	2	3,5	1,99	0,78
65	76,1	145	185	16	92	18	2	4	14	122	77	33	8	88	2	3,5	2,41	1,05
80	88,9	160	200	18	106	18	2	8	16	138	90	38	8	102	2	3,7	2,90	1,48
100	114,3	180	220	18	130	18	2	8	16	158	115,5	38	9	126	2	3,7	3,20	1,63
125	139,7	210	250	18	156	18	3	8	18	188	141	40	10	152	3	4	3,95	2,37
150	168,3	240	285	18	184	22	3	8	18	212	170,5	41	13	180	3	5	4,82	2,70
200	219,1	295	340	20	237	22	3	12	20	268	221	45	13	233	3	5	6,60	4,23
250	273	355	405	24	291	25	3	12	22	320	275	51	16	287	3	5,5	10,6	5,76
300	323,9	410	460	28	344	25	3	12	24	378	326	58	18	340	3	6	14,8	8,62
350	355,6	470	520	32	381	25	4	16	26	438	357,5	64	18	376	4	6,4	22,7	14,6
400	406,4	525	580	36	434	30	4	16	28	490	408,5	71	18	429	4	7	29,7	18,9
450	457,2	585	640	40	490	30	4	20	30	550	459	77	18	485	4	7,3	34,4	25,4
500	508	650	715	44	545	33	5	20	32	610	510	83	18	540	5	7,3	52,2	32,8

Flange libere con collare d'appoggio da saldare in testa

UNI 2292-67 PN. 25 - UNI 2293-67 PN. 40

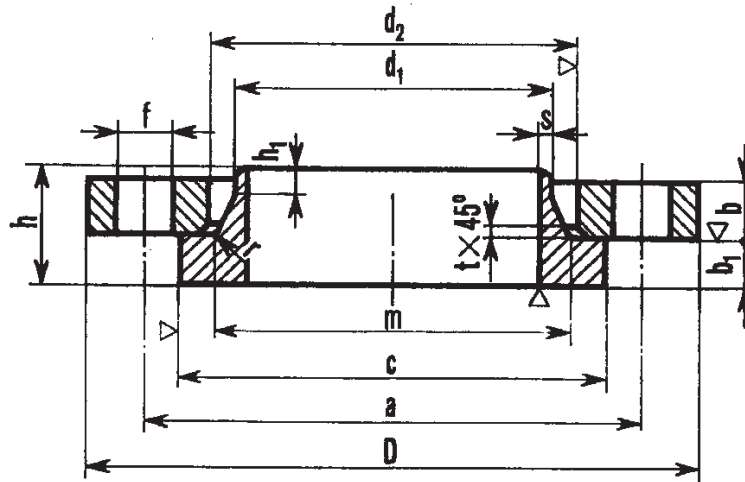

DN	Ø TUBO	FLANGIA							COLLARE							Kg.	
		a	D	b	d ₂	f	t	FORI	b ₁	c	d ₁	h	h ₁	m	r	s	FLANGE

UNI 2292-67 PN. 25

50	60,3	125	165	20	76	18	2	4	16	102	61,5	40	10	72	2	3,5	2,50	0,91
65	76,1	145	185	20	92	18	2	8	16	122	77	40	10	88	2	3,5	2,85	1,21
80	88,9	160	200	22	106	18	2	8	18	138	90	44	11	102	2	3,7	3,55	1,66
100	114,3	190	235	22	134	22	2	8	20	162	115,5	46	11	130	2	3,7	4,53	2,22
125	139,7	220	270	24	162	25	3	8	22	188	141	50	11	158	3	4	6,16	3,03
150	168,3	250	300	24	190	25	3	8	22	218	170,5	51	12	186	3	5	7,23	3,83
200	219,1	310	360	26	243	25	3	12	24	278	221	55	12	239	3	5	10,1	6,15
250	273	370	425	30	297	30	3	12	26	335	275	62	14	293	3	5,5	15,1	8,82
300	323,9	430	485	34	352	30	3	16	28	390	326	68	14	348	3	6	20,0	12,3
350	355,6	490	555	38	387	33	4	16	32	450	357,5	76	14	382	4	6,4	33,0	20,6
400	406,4	550	620	42	439	36	4	16	34	505	408,5	83	16	434	4	7,3	44,0	26,6
450	457,2	600	670	46	500	36	4	20	36	555	459	90	16	495	4	8	49,0	33,6
500	508	660	730	50	550	36	5	20	38	615	510	96	16	545	5	8	60,0	41,9

UNI 2293-67 PN. 40

50	60,3	125	165	20	76	18	2	4	16	102	61,5	40	10	72	2	3,5	2,48	0,91
65	76,1	145	185	20	92	18	2	8	16	122	77	40	10,5	88	2	3,5	2,85	1,21
80	88,9	160	200	22	106	18	2	8	18	138	90	44	11	102	2	3,7	3,55	1,66
100	114,3	190	235	22	134	22	2	8	20	162	115,5	46	11	130	2	3,7	4,53	2,22
125	139,7	220	270	24	162	25	3	8	22	188	141	50	11	158	3	4	6,16	3,03
150	168,3	250	300	24	190	25	3	8	22	218	170,5	51	11,5	186	3	5	7,23	3,83
200	219,1	320	375	30	245	30	3	12	26	285	221	62	12	241	3	5,5	12,9	7,68
250	273	385	450	36	303	33	3	12	30	345	275	73	13	299	3	6,5	21,7	12,4
300	323,9	450	515	40	360	33	4	16	34	410	326	81	13,5	356	4	7,3	29,1	19,7
350	355,6	510	580	46	395	36	4	16	38	465	357,5	92	14,5	390	4	8	45,3	30,0
400	406,4	585	660	50	450	39	5	16	42	535	408,5	101	14,5	445	5	9	64,3	44,1

Flange libere con anello d'appoggio da saldare a sovrapposizione UNI 6088-67 PN. 6

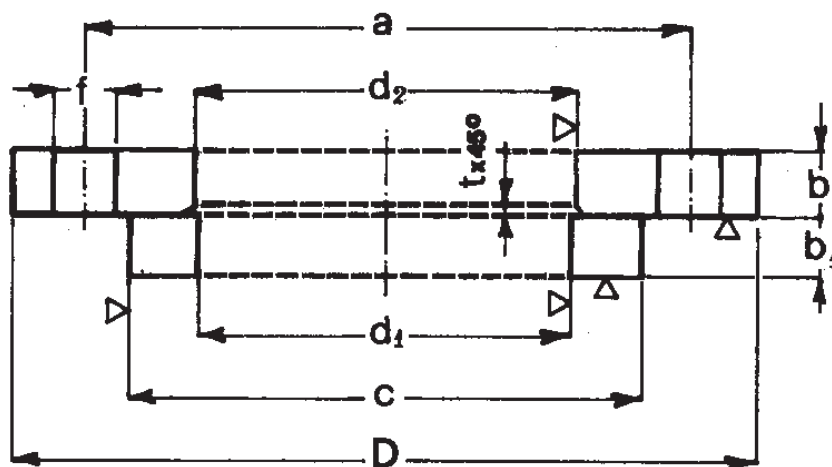

DN	Ø DIN	TUBO ISO	FLANGIA LIBERA								ANELLO				Tubo Bordato		VITI	Kg.	
			a	D	b	d ₂	f	t	FORI	b ₁	c	d ₁	c	r	FLANGE	ANELLO			
25	30	33,7	75	100	12	33	37	11	4	4	10	60	30,5	34,0	60	6	M10	0,61	0,16
32	38	42,4	90	120	12	41	46	14	4	4	10	70	38,5	43,0	70	6	M12	0,87	0,21
40	44,5	48,3	100	130	12	48	52	14	4	4	10	80	45,0	49,0	80	6	M12	1,01	0,27
50	57	60,3	110	140	12	62	64	14	4	4	12	90	58,0	61,5	90	6	M12	1,09	0,35
65	76,1		130	160	12	80		14	4	4	12	110	77,0		110	6	M12	1,34	0,45
80	88,9		150	190	14	94		18	5	4	14	128	90,0		128	7	M16	2,21	0,71
100	108	114,3	170	210	14	113	119	18	5	4	14	148	109,0	115,5	148	7	M16	2,55	0,86
125	133	139,7	200	240	14	138	145	18	5	8	14	178	134,5	141,0	178	7	M16	3,06	1,17
150	159	168,3	225	265	14	164	174	18	5	8	14	202	160,5	170,0	202	7	M16	3,46	1,29
200	219,1		280	320	18	225		18	5	8	16	258	221,0		258	7	M16	5,03	1,75
250	267	273	335	375	20	273	279	18	5	12	18	312	269,0	275,0	312	7	M16	7,58	2,77
300	323,9		395	440	24	330		22	5	12	18	365	326,0		365	7	M20	11,6	2,99
350	368	355,6	445	490	26	374	362	22	5	12	18	415	370,5	358,0	415	7	M20	16,4	4,89
400	419	406,4	495	540	28	426	413	22	6	16	20	465	422,0	409,0	465	8	M20	19,4	6,03
450	457,2		550	595	30	464		22	6	16	20	520	460,2		520	8	M20	24,0	9,03
500	508		600	645	32	515		22	6	20	22	570	511,0		570	8	M20	27,6	10,9
600	609,6		705	755	36	618		25	6	20					670	8	M22	38,7	
700	711,2		810	860	40	721		25	6	24					775	8	M22	50,2	
800	812,8		920	975	44	824		30	6	24					880	8	M27	67,5	
900	914,4		1020	1075	48	927		30	6	24					980	8	M27	80,9	
1000	1016		1120	1175	52	1031		30	6	28					1080	8	M27	93,3	

Flange libere con anello d'appoggio da saldare a sovrapposizione UNI 6089-67 PN. 10

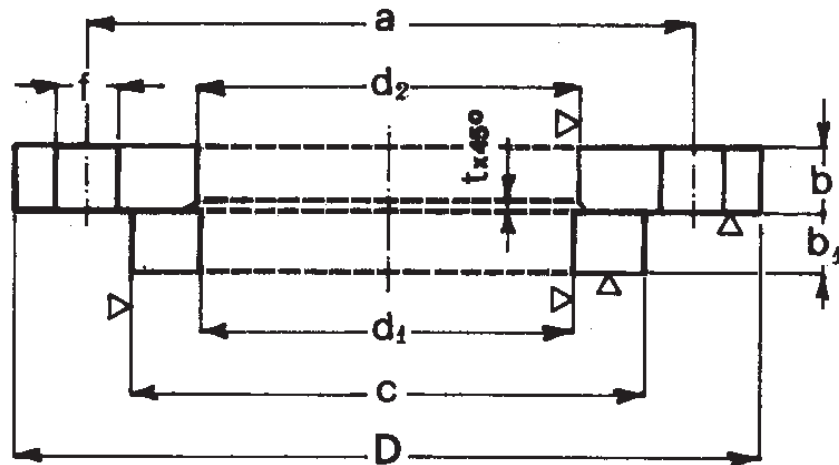

DN	Ø DIN	TUBO ISO	FLANGIA LIBERA								ANELLO			Tubo Bordato		VITI	Kg.		
			a	D	b	DIN d ₂ ISO	f	t	FORI	b ₁	c	d ₁	c	r	FLANGE		ANELLO		
25	30	33,7	85	115	16	33	37	14	4	4	12	68	30,5	34	68	6	M12	1,11	0,27
32	38	42,4	100	140	16	41	46	18	4	4	12	78	38,5	43	78	6	M16	1,63	0,34
40	44,5	48,3	110	150	16	48	52	18	4	4	12	88	45	49	88	6	M16	1,85	0,42
50	57	60,3	125	165	16	62	64	18	4	4	14	102	58	61,5	102	6	M16	2,16	0,60
65	76,1		145	185	16	80		18	4	4	14	122	77		122	6	M16	2,60	0,77
80	88,9		160	200	18	94		18	5	4	16	138	90		138	7	M16	3,14	1,07
100	108	114,3	180	220	18	113	119	18	5	8	16	158	109	115,5	158	7	M16	3,63	1,29
125	133	139,7	210	250	18	138	145	18	5	8	18	188	134,5	141	188	7	M16	4,49	1,91
150	159	168,3	240	285	18	164	174	22	5	8	18	212	160,5	170	212	7	M20	5,54	2,12
200	219,1		295	340	20	225		22	5	8	20	268	221		268	7	M20	7,46	2,83
250	267	273	350	395	22	273	279	22	5	12	22	320	269	275	320	7	M20	10,2	4,07
300	323,9		400	445	26	330		22	5	12	22	370	326		370	7	M20	13,2	4,15
350	368	355,6	460	505	28	374	362	22	5	16	22	430	370,5	358	430	7	M20	19,9	7,70
400	419	406,4	515	565	32	426	413	25	6	16	24	482	422	409	482	8	M22	27,2	9,60
450	457,2		565	615	34	464		25	6	20	24	532	460,2		532	8	M22	31,3	12,7
500	508		620	670	38	515		25	6	20	26	585	511		585	8	M22	39,9	15,7
600	609,6		725	780	44	618		30	6	20	26	685	615		685	8	M27	56,3	18,7
700	711,2		840	895	50	721		30	6	24	28	800	717,5		800	8	M27	79,7	27,3
800	812,8		950	1015	56	824		33	6	24	30	905	819,2		905	8	M30	112	34,9

Flange libere con anello d'appoggio da saldare a sovrapposizione UNI 6090-67 PN. 16

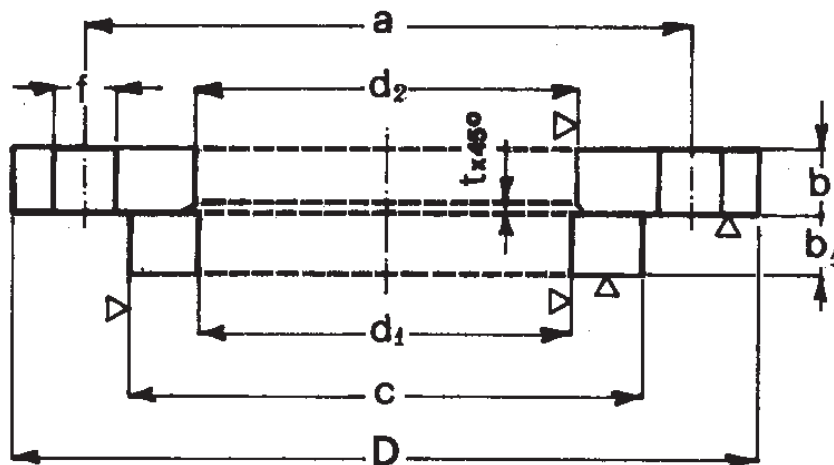

DN	Ø DIN	TUBO ISO	FLANGIA LIBERA								ANELLO			Tubo Bordato		VITI	Kg.		
			a	D	b	DIN d ₂ ISO	f	t	FORI	b ₁	c	d ₁	c	r	FLANGE		ANELLO		
25	30	33,7	85	115	16	33	37	14	4	4	12	68	30,5	34	68	6	M12	1,11	0,27
32	38	42,4	100	140	16	41	46	18	4	4	12	78	38,5	43	78	6	M16	1,63	0,34
40	44,5	48,3	110	150	16	48	52	18	4	4	12	88	45	49	88	6	M16	1,85	0,42
50	57	60,3	125	165	16	62	64	18	4	4	14	102	58	61,5	102	6	M16	2,16	0,60
65	76,1		145	185	16	80		18	4	4	14	122	77		122	6	M16	2,60	0,77
80	88,9		160	200	18	94		18	5	8	16	138	90		138	7	M16	3,14	1,07
100	108	114,3	180	220	18	113	119	18	5	8	16	158	109	115,5	158	7	M16	3,63	1,29
125	133	139,7	210	250	18	138	145	18	5	8	18	188	134,5	141	188	7	M16	4,49	1,91
150	159	168,3	240	285	18	164	174	22	5	8	18	212	160,5	170	212	7	M20	5,54	2,12
200	219,1		295	340	20	225		22	5	12	20	268	221		268	7	M20	7,22	2,84
250	267	273	355	405	24	273	279	25	5	12	22	320	269	275	320	7	M22	12,0	4,07
300	323,9		410	460	28	330		25	5	12	24	378	326		378	7	M22	16,3	5,41
350	368	355,6	470	520	32	374	362	25	5	16	26	438	370,5	358	438	7	M22	25,4	10,2
400	419	406,4	525	580	36	426	413	30	6	16	28	490	422	409	490	8	M27	33,4	12,6
450	457,2		585	640	40	464		30	6	20	30	550	460,2		550	8	M27	43,3	19,5
500	508		650	715	44	515		33	6	20	32	610	511		610	8	M30	60,6	25,3
600	609,6		770	840	48	618		36	6	20							M33	88,0	
700	711,2		840	910	52	721		36	6	24							M33	96,0	
800	812,8		950	1025	56	824		39	6	24							M36	125	
900	914,4		1050	1125	60	927		39	6	28							M36	150	

Flange libere con anello d'appoggio da saldare in sovrapposizione

UNI 2299-67 PN. 25 / UNI 2300-67 PN. 40

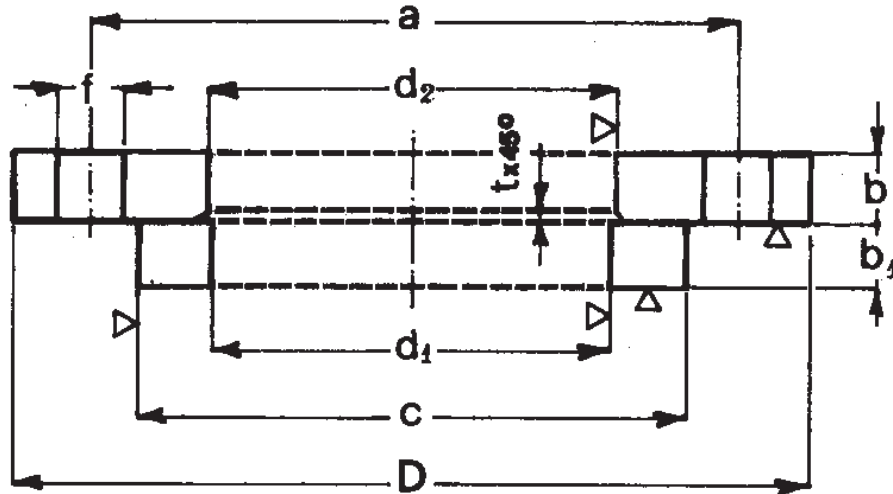

DN	Ø DIN	TUBO ISO	FLANGIA LIBERA							ANELLO			VITI	Kg.	
			a	D	b	DIN d ₂ ISO	f	t	FORI	b ₁	c	d ₁		FLANGIA	ANELLO

UNI 2299-67 PN. 25 DAL DN 50 AL DN 150 USARE FLANGE PN. 40 - UNI 2300-67

200	219,1		310	360	26	225		25	5	12	24	278	221		M22	11,4	4,20
250	267	273	370	425	30	273	279	30	5	12	26	335	269	275	M27	17,5	6,39
300	323,9		430	485	34	330		30	5	16	28	390	326		M27	23,3	7,91
350	368	355,6	490	555	38	374	362	33	5	16	32	450	370,5	358	M30	37,4	14,7
400	419	406,4	550	620	42	426	413	36	6	16	34	505	422	409	M33	49,8	18,4
450	457,2		600	670	46	464		36	6	20	36	555	460,2		M33	58,7	24,6
500	508		660	730	50	515		36	6	20	38	616	511		M33	74,3	31,4

UNI 2300-67 PN. 40

25	30	33,7	85	115	18	33	37	14	4	4	14	68	30,5	34	M12	1,25	0,32
32	38	42,4	100	140	18	41	46	18	4	4	14	78	38,5	43	M16	1,83	0,40
40	44,5	48,3	110	150	18	48	52	18	4	4	14	88	45	49	M16	2,08	0,49
50	57	60,3	125	165	20	62	64	18	4	4	16	102	58	61,5	M16	2,71	0,69
65	76,1		145	185	20	80		18	4	8	16	122	77		M16	3,09	0,88
80	88,9		160	200	22	94		18	5	8	18	138	90		M16	3,84	1,21
100	108	114,3	190	235	22	113	119	22	5	8	20	162	109	115,5	M20	5,20	1,77
125	133	139,7	220	270	24	138	145	25	5	8	22	188	134,5	141	M22	7,18	2,34
150	159	168,3	250	300	24	164	174	25	5	8	22	218	160,5	170	M22	8,54	2,95
200	219,1		320	375	30	225		30	5	12	26	285	221		M27	14,6	5,19
250	267	273	385	450	36	273	279	33	5	12	30	345	269	275	M30	25,4	8,63
300	323,9		450	515	40	330		33	5	16	34	410	326		M30	34,1	13,0
350	368	355,6	510	580	46	374	362	36	5	16	38	465	370,5	358	M33	52,2	20,6
400	419	406,4	585	660	50	426	413	39	6	16	42	535	422	409	M36x3	74,0	30,8

Flange filettate a collare

UNI 2253-67 PN. 6

UNI 2254-67 PN. 16



UNI 2253

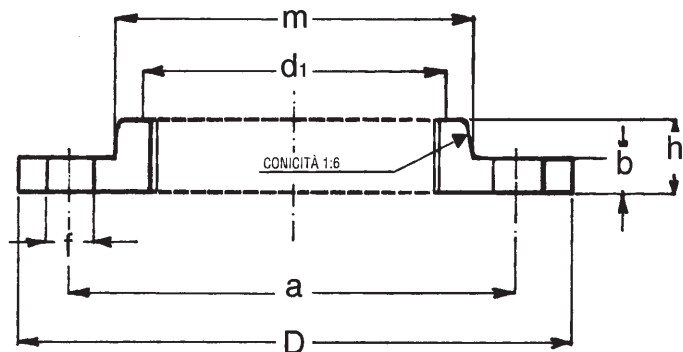

UNI 2254

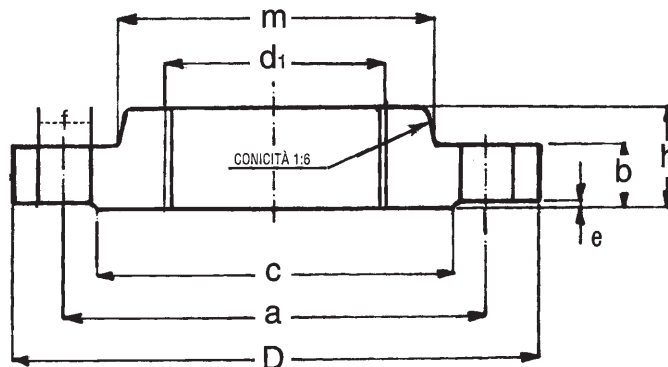

Ø	DN	a	D	b	d ₁	f	h	m	VITI	N. FORI	Kg.
---	----	---	---	---	----------------	---	---	---	------	---------	-----

UNI 2253-67 PN. 6

3/8"	10	50	75	12	3/8"	11	20	25	M10	4	0,39
1/2"	15	55	80	12	1/2"	11	20	30	M10	4	0,43
3/4"	20	65	90	14	3/4"	11	24	40	M10	4	0,66
1"	25	75	100	14	1"	11	24	50	M10	4	0,82
1 1/4"	32	90	120	14	1 1/4"	14	26	60	M12	4	1,17
1 1/2"	40	100	130	14	1 1/2"	14	26	70	M12	4	1,40
2"	50	110	140	14	2"	14	28	80	M12	4	1,59
2 1/2"	65	130	160	14	2 1/2"	14	32	100	M12	4	2,17
3"	80	150	190	16	3"	18	34	110	M16	4	3,20
4"	100	170	210	16	4"	18	38	130	M16	4	3,59
5"	125	200	240	18	5"	18	40	160	M16	8	4,94
6"	150	225	265	18	6"	18	44	185	M16	8	5,83

UNI 2254-67 PN. 16

3/8"	10	60	90	14	3/8"	14	20	30	M12	4	0,63
1/2"	15	65	95	14	1/2"	14	20	35	M12	4	0,70
3/4"	20	75	105	16	3/4"	14	24	45	M12	4	1,01
1"	25	85	115	16	1"	14	24	52	M12	4	1,21
1 1/4"	32	100	140	16	1 1/4"	18	26	60	M16	4	1,76
1 1/2"	40	110	150	16	1 1/2"	18	26	70	M16	4	2,04
2"	50	125	165	18	2"	18	28	85	M16	4	2,85
2 1/2"	65	145	185	18	2 1/2"	18	32	105	M16	4	3,53
3"	80	160	200	20	3"	18	34	118	M16	8	4,24
4"	100	180	220	20	4"	18	38	140	M16	8	4,90
5"	125	210	250	22	5"	18	40	168	M16	8	6,63
6"	150	240	285	22	6"	22	44	195	M20	8	8,49

Flange filettate a collare

UNI 2255-67 PN. 40

UNI 2256-67 PN. 64 - UNI 2257-67 PN. 100

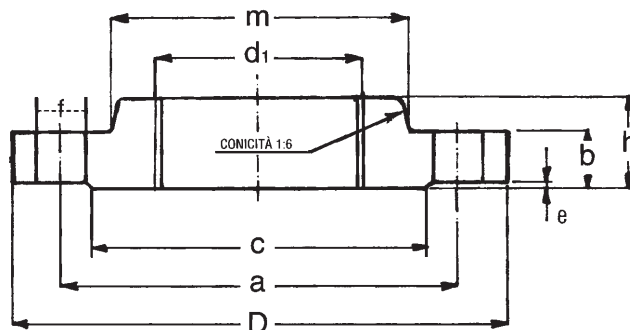

Ø	DN	a	D	b	d ₁	f	h	m	c	e	VITI	N. FORI	Kg.
---	----	---	---	---	----------------	---	---	---	---	---	------	---------	-----

UNI 2255-67 PN. 40

3/8"	10	60	90	16	3/8"	14	22	30	40	2	M12	4	0,72
1/2"	15	65	95	16	1/2"	14	22	35	45	2	M12	4	0,80
3/4"	20	75	105	18	3/4"	14	26	45	58	2	M12	4	1,13
1"	25	85	115	18	1"	14	28	52	68	2	M12	4	1,37
1 1/4"	32	100	140	18	1 1/4"	18	30	60	78	2	M16	4	1,99
1 1/2"	40	110	150	18	1 1/2"	18	32	70	88	3	M16	4	2,35
2"	50	125	165	20	2"	18	34	85	102	3	M16	4	3,11
2 1/2"	65	145	185	22	2 1/2"	18	38	105	122	3	M16	8	4,10
3"	80	160	200	24	3"	18	40	118	138	3	M16	8	5,06
4"	100	190	235	24	4"	22	44	145	162	3	M20	8	6,81
5"	125	220	270	26	5"	25	48	170	188	3	M22	8	9,25
6"	150	250	300	28	6"	25	52	200	218	3	M22	8	12,10

UNI 2256-67 PN. 64

DAL Ø 3/8 " AL Ø 1 1/2" USARE FLANGE PN. 100 - UNI 2257-67

2"	50	135	180	26	2"	22	36	90	95	3	M20	4	4,23
2 1/2"	65	160	205	26	2 1/2"	22	40	112	120	3	M20	8	5,41
3"	80	170	215	28	3"	22	44	125	130	3	M20	8	6,35
4"	100	200	250	30	4"	25	52	152	160	3	M22	8	9,18
5"	125	240	295	34	5"	30	56	185	185	3	M27	8	14,0
6"	150	280	345	36	6"	33	60	215	215	3	M30	8	20,3

UNI 2257-67 PN. 100

3/8"	10	70	100	20	3/8"	14	28	40	40	2	M12	4	1,07
1/2"	15	75	105	20	1/2"	14	28	43	45	2	M12	4	1,18
3/4"	20	90	130	22	3/4"	18	30	52	58	2	M16	4	1,98
1"	25	100	140	24	1"	18	32	60	65	2	M16	4	2,51
1 1/4"	32	110	155	24	1 1/4"	22	32	68	75	2	M20	4	2,97
1 1/2"	40	125	170	26	1 1/2"	22	34	80	85	3	M20	4	3,82
2"	50	145	195	28	2"	25	36	95	95	3	M22	4	5,33
2 1/2"	65	170	220	30	2 1/2"	25	40	118	120	3	M22	8	7,00
3"	80	180	230	32	3"	25	44	130	130	3	M22	8	8,10
4"	100	210	265	36	4"	30	52	158	160	3	M27	8	11,7
5"	125	250	315	40	5"	33	56	188	185	3	M30	8	18,2
6"	150	290	355	44	6"	33	60	225	215	3	M30	12	24,6

Superfici di tenuta a gradino



UNI 2229-67

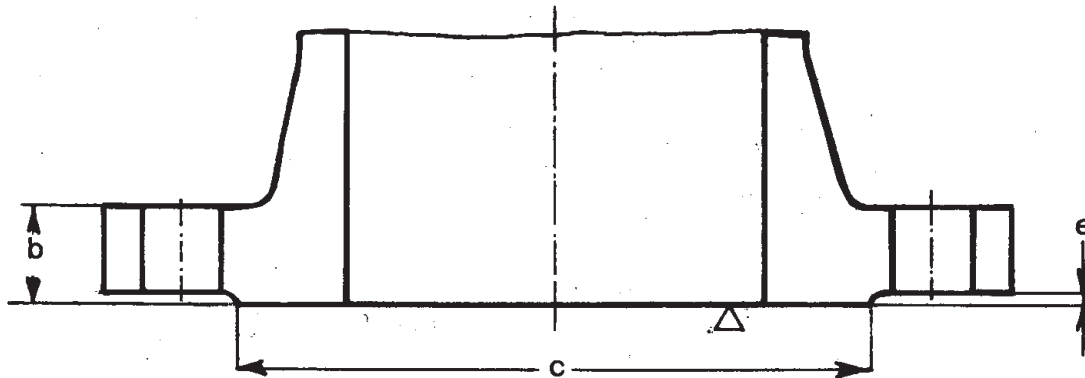

DN	e	PN 2,5	PN. 6	PN. 10	PN. 16	PN. 25	PN. 40	PN. 64	PN. 100	PN. 160	PN. 250
		c									
10	2	35	35	40	40	40	40	40	40	40	40
15	2	40	40	45	45	45	45	45	45	45	45
20	2	50	50	58	58	58	58	58	58	58	58
25	2	60	60	68	68	68	68	65	65	65	65
32	2	70	70	78	78	78	78	75	75	75	75
40	3	80	80	88	88	88	88	85	85	85	85
50	3	90	90	102	102	102	102	95	95	95	95
65	3	110	110	122	122	122	122	120	120	120	120
80	3	128	128	138	138	138	138	130	130	130	130
100	3	148	148	158	158	162	162	160	160	160	160
125	3	178	178	188	188	188	188	185	185	185	185
150	3	202	202	212	212	218	218	215	215	215	215
200	3	258	258	268	268	278	285	270	270	280	300
250	3	312	312	320	320	335	345	325	325	325	350
300	4	365	365	370	378	390	410	375	375	375	
350	4	415	415	430	438	450	465	435	435		
400	4	465	465	482	490	505	535	485	485		
450	4	520	520	532	550	555	560	535	535		
500	4	570	570	585	610	615	615	590	590		
600	5	670	670	685	725	720	735	700	700		
700	5	775	775	800	795	820	840	810	810		
800	5	880	880	905	900	930	960	920			
900	5	980	980	1005	1000	1030	1070	1030			
1000	5	1080	1080	1110	1115	1140	1180	1140			
1200	5	1280	1295	1330	1330	1350	1380	1350			
1400	5	1480	1510	1535	1530	1560	1600				
1600	5	1690	1710	1760	1750	1780	1815				
1800	5	1890	1920	1960	1950	1985					
2000	5	2090	2125	2170	2150	2210					

1) La quota «b» indica che il gradino è ricavato dallo spessore della flangia.

Incastro UNI 2225-67



Esecuzione SM* e SF**

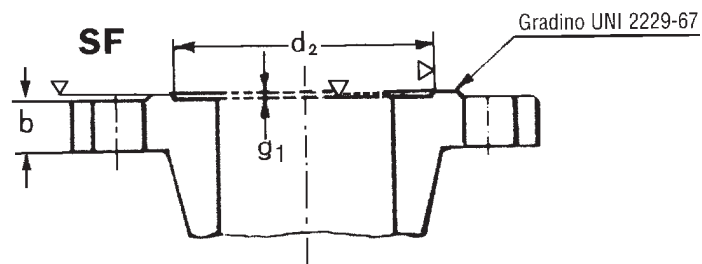
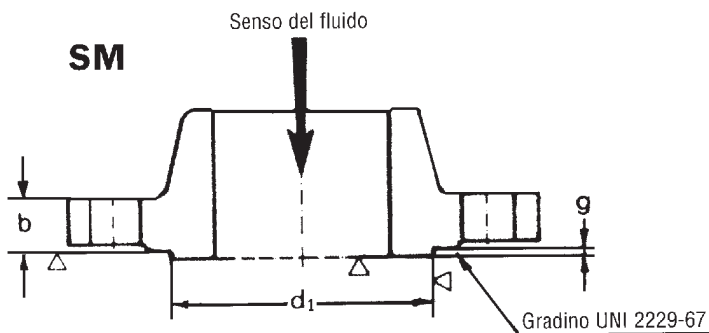

DN	PN. ≤ 6		PN. ≥ 10		g	NOTE
	d ₁	d ₂	d ₁	d ₂		
10	30	31	34	35	4	*) SM = Semplice maschio **) SF = Semplice femmina Tolleranze: d ₁ = + 0 - 0,5 d ₂ = + 0,5 - 0 g = + 0,5 - 0 g ₁ = + 0 - 0,5
15	35	36	39	40	4	
20	42	43	50	51	4	
25	49	50	57	58	4	
32	61	62	65	66	4	
40	68	69	75	76	4	
50	81	82	87	88	4	
65	101	102	109	110	4	
80	117	118	120	121	4	
100	137	138	149	150	4,5	
125	165	166	175	176	4,5	
150	192	193	203	204	4,5	
200	249	250	259	260	4,5	
250	304	305	312	313	4,5	
300	354	355	363	364	4,5	
350	401	402	421	422	5	
400	451	452	473	474	5	
450	505	506	523	524	5	
500	555	556	575	576	5	
600	655	656	675	676	5	
700	760	761	777	778	5	
800	865	866	882	883	5	
900	965	966	987	988	5	
1000	1062	1063	1091	1092	6	
1200	1263	1265	1292	1294	6	
1400	1463	1465	1492	1494	6	
1600	1672	1674	1698	1700	6	
1800	1872	1874	1898	1900	6	
2000	2072	2074	2098	2100	6	

Incastro UNI 2226-67



Esecuzione DM* e DF**

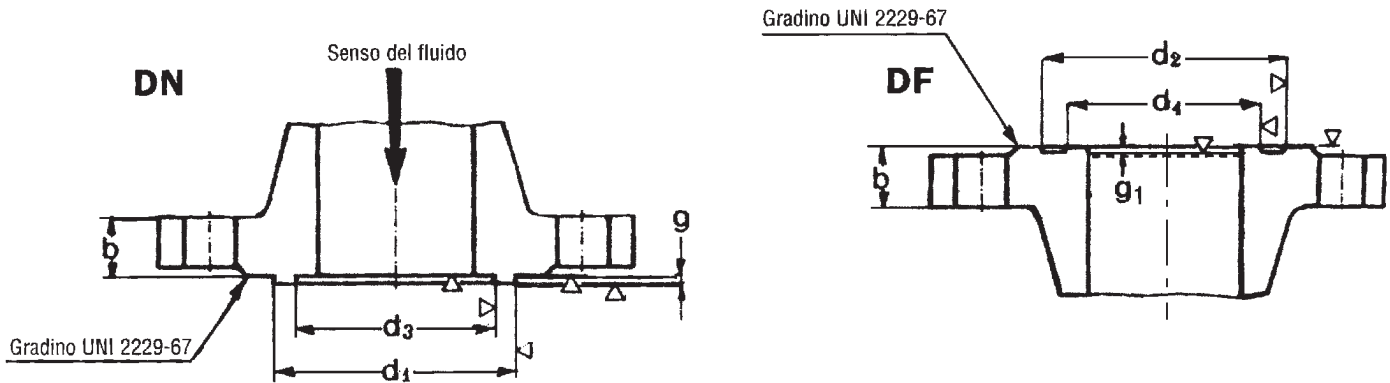

DN	PN. ≤ 6				PN. ≥ 10				g	NOTE
	d ₁	d ₂	d ₃	d ₄	d ₁	d ₂	d ₃	d ₄		
10	30	31	22	21	34	35	24	23	4	*) DM = Doppio maschio **) DF = Doppio femmina Tolleranze: d ₁ = + 0 - 0,5 d ₂ = + 0,5 - 0 d ₃ = + 0,5 - 0 d ₄ = + 0 - 0,5 g = + 0,5 - 0 g ₁ = + 0 - 0,5
15	35	36	27	26	39	40	29	28	4	
20	42	43	32	31	50	51	36	35	4	
25	49	50	39	38	57	58	43	42	4	
32	61	62	49	48	65	66	51	50	4	
40	68	69	56	55	75	76	61	60	4	
50	81	82	69	68	87	88	73	72	4	
65	101	102	89	88	109	110	95	94	4	
80	117	118	103	102	120	121	106	105	4	
100	137	138	123	122	149	150	129	128	4,5	
125	165	166	149	148	175	176	155	154	4,5	
150	192	193	176	175	203	204	183	182	4,5	
200	249	250	231	230	259	260	239	238	4,5	
250	304	305	286	285	312	313	292	291	4,5	
300	354	355	336	335	363	364	343	342	4,5	
350	401	402	381	380	421	422	395	394	5	
400	451	452	431	430	473	474	447	446	5	
450	505	506	481	480	523	524	497	496	5	
500	555	556	531	530	575	576	549	548	5	
600	655	656	631	630	675	676	649	648	5	
700	760	761	736	735	777	778	751	750	5	
800	865	866	841	840	882	883	856	855	5	
900	965	966	941	940	987	988	961	960	5	
1000	1062	1063	1036	1035	1091	1092	1061	1060	6	
1200	1263	1265	1237	1235	1292	1294	1262	1260	6	
1400	1463	1465	1437	1435	1492	1494	1462	1460	6	
1600	1672	1674	1642	1640	1698	1700	1662	1660	6	
1800	1872	1874	1842	1840	1898	1900	1862	1860	6	
2000	2072	2074	2042	2040	2098	2100	2062	2060	6	